

NET METERING SYSTEMS

1.0 INDEX

- 1.0 INDEX
- 2.0 PURPOSE
- 3.0 GENERAL
- 4.0 APPLICABLE STANDARDS
- 5.0 DEFINITIONS
- 6.0 STUDIES
- 7.0 METERING ARRANGEMENTS
- 8.0 CUSTOMER ENGINEERING REQUIREMENTS
- 9.0 CUSTOMER OPERATING REQUIREMENTS
- 10.0 ATTACHMENTS

2.0 PURPOSE

The purpose of the document is to present the Utility's design requirements for Net Metering systems to operate in parallel with the Utility's electric system to ensure the safety of people and property and the integrity of the electric system

3.0 GENERAL

As defined in NRS 704-771: "Net metering system" means facility or energy system for the generation of electricity that:

- (a) Uses renewable energy as its primary source of energy to generate electricity;
- (b) Has a generating capacity of not more than 30 kilowatts;
- (c) Is located on the customer-generator's premises;
- (d) Operates in parallel with the utility's transmission and / or distribution facilities; and
- (e) Is intended primarily to offset part or all of the customer-generator's requirements for electricity.

As defined in NRS 704.7811: “Renewable energy” means:

- (a) Biomass;
- (b) Biogas
- (c) Geothermal energy;
- (d) Solar energy;
- (e) Waterpower; and
- (f) Wind

4.0 APPLICABLE STANDARDS

A Net Metering system used by a customer-generator must meet all applicable safety and power quality standards established by:

- (a) The National Electrical Code, especially Articles 685, 690 and 705,
- (b) All applicable State and local codes,
- (c) Underwriters Laboratories Inc.; and
- (d) The Institute of Electrical and Electronic Engineers, (IEEE) Standards 929 and 1547 having a particular application. The optional, visible break and lockable disconnect switch of IEEE 1547 are required. Pull-out disconnect is **NOT** acceptable.

5.0 DEFINITIONS

- (a) “Customer – Generator” means a user of a Net Metering system.
- (b) “Net Metering” means measuring and billing only the difference between electricity supplied by the utility and the electricity generated by the customer – generator that is fed back to the utility over the applicable billing period.

					ENGINEERING & CONSTRUCTION STANDARD		SHEET 2 OF 6	
					NET METERING SYSTEM		VOLUME 5	
					DESIGN AND OPERATING PROCEDURES		DRAWING NUMBER	
					FOR CUSTOMER GENERATORS		ENG03U	
DRAWN	DESIGN	SUPR	DATE	REV				
JL	KS	SJ	08/04	00				

6.0 STUDIES

Neither an Interconnection Study nor a Detailed Impact Study is required.

7.0 METERING ARRANGEMENT

- (a) The Revenue Net Metering will be arranged so that utility measures the net electricity produced or consumed during the billing period.
- (b) A second meter will measure the electricity generated by the customer-generator, if the customer elects to sell renewable energy credits.

8.0 CUSTOMER ENGINEERING REQUIREMENTS

This section provides the engineering requirements that the customer must comply with to install a 'Net metering' system:

- (a) Locate the REC meter per the attached drawing.
- (b) Locate the Utility Source disconnect switch per the attached drawing.
- (c) Install the above within 10' of the Net Meter.

9.0 CUSTOMER OPERATING REQUIREMENTS

This section provides the operating requirements that the customer must follow and the responsibilities that the customer must assume for operating their generation in parallel to the utility system:

- 9.1 Quality of service – The operation of the customer's generation facility must not reduce the quality of service to the utility's electric system or other Utility customers. No abnormal voltages, currents, frequencies, or interruptions are permitted.
- 9.2 De-energized utility Circuit – The customer will at no time energize a de-energized utility circuit.

9.3 Inhibited Parallel Operation – If while operating parallel to utility’s system, any of the protective devices operate inhibiting parallel operation, the customer will perform the following procedures prior to attempting any further parallel operation with utility:

9.3.1 Determine whether utility’s circuit is energized or de-energized.

9.3.2 If utility’s circuit has been continuously energized, then the customer will not attempt to reconnect their system in parallel with the utility until the cause of a protective device mis-operation has been corrected by a certified person and the utility has inspected and has satisfied itself that the customer’s system is operating properly.

9.3.3 If it is determined that the utility circuit is de-energized, the customer must not attempt to reconnect their system until it is confirmed by utility that power has been restored and utility’s circuit is energized.

9.3.4 The customer is not prohibited from isolating their system from utility and supplying their own premise wiring while utility’s circuit de-energized.

9.4 The customer is responsible for damage caused to other customers and to utility as a result of improper operation or malfunction of their generation facilities.

9.5 Utility is not responsible for damage caused to the customer’s facility as a result of events over which utility has no control.

9.6 It is recommended that on the loss of power from the utility, the customer- generator isolate itself from the utility. The customer generator shall delay the reconnection to the utility for one minute after the utility voltage and frequency are restored to normal. Utility is not responsible for damage caused to the customer’s facility as a result of the utilities automatic or manual reclosing of its feeder.



ENGINEERING & CONSTRUCTION STANDARD

SHEET 4 OF 6

NET METERING SYSTEM

VOLUME 5

DESIGN AND OPERATING PROCEDURES
FOR CUSTOMER GENERATORS

DRAWING NUMBER
ENG03U

DRAWN	DESIGN	SUPR	DATE	REV
JL	KS	SJ	08/04	00

10.0 ATTACHMENTS

Metering One-Line Diagram

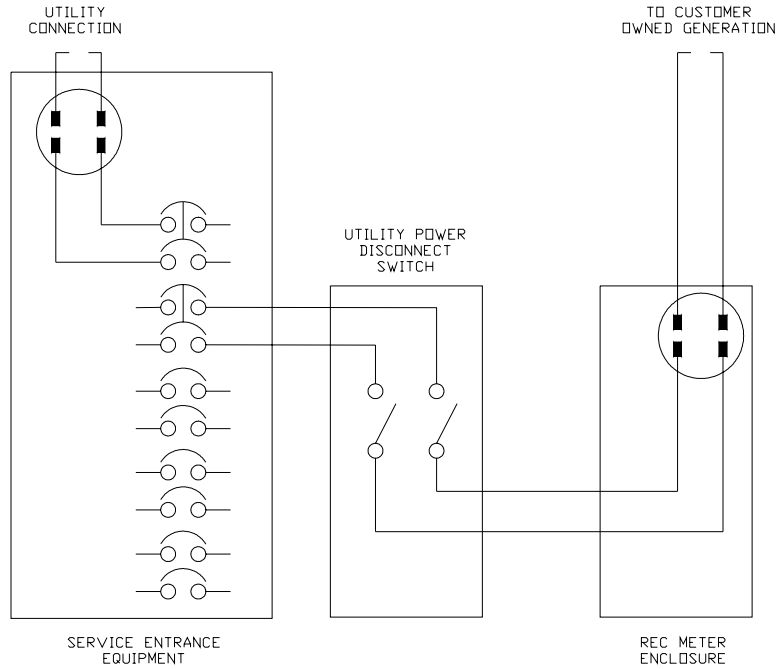

Metering Arrangement

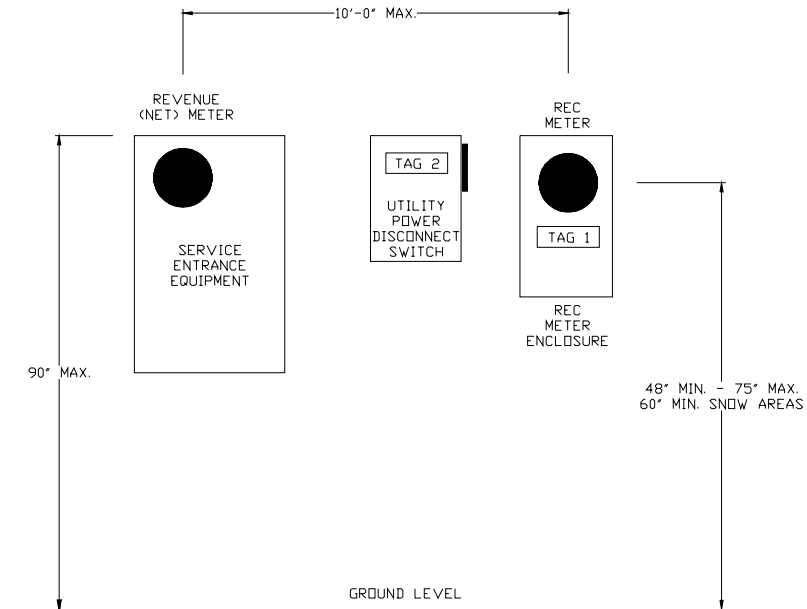

DRAWN	DESIGN	SUPR	DATE	REV
JL	KS	SJ	08/04	00

ENGINEERING & CONSTRUCTION STANDARD

NET METERING SYSTEM

DESIGN AND OPERATING PROCEDURES

FOR CUSTOMER GENERATORS

SHEET 5 OF 6

VOLUME 5

DRAWING NUMBER
ENG03U

Required Tagging

Tag 1. Install On Meter Box



Tag 2. Install On Disconnect Switch Box

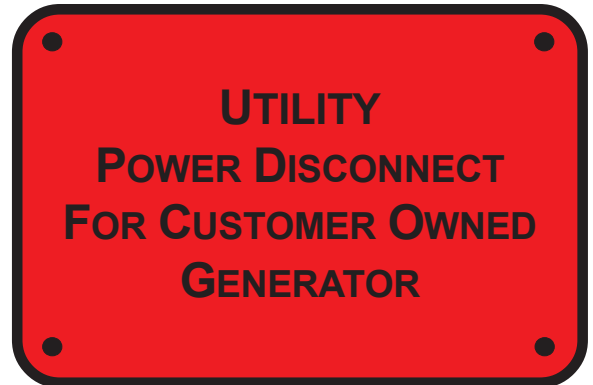

Tag 3. Install On Transformer, J-Bar Or Service Conductor

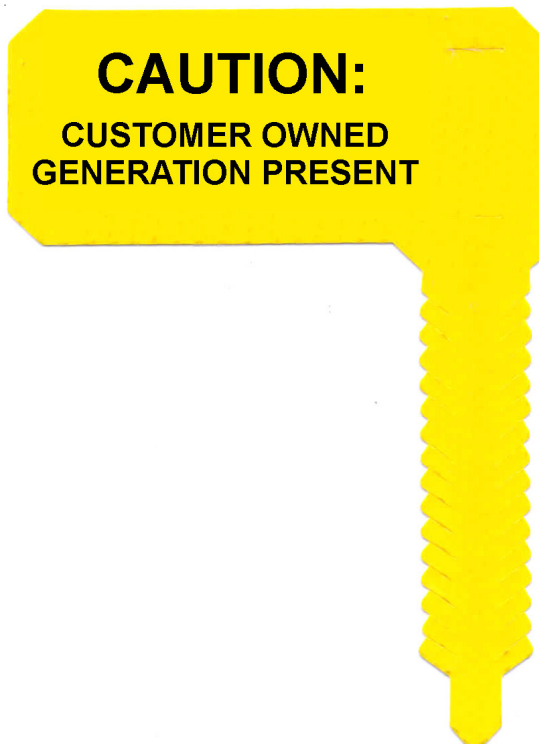

Tag 4. Install On Net Meter

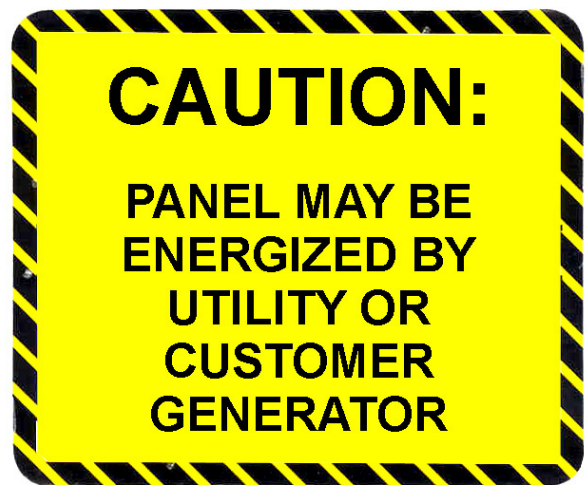

DRAWN	DESIGN	SUPR	DATE	REV
JL	KS	SJ	08/04	00