

COMMERCIAL - INDUSTRIAL SERVICES

1.0 INDEX

- 1.0 INDEX
- 2.0 PURPOSE
- 3.0 GENERAL REQUIREMENTS
- 4.0 OVERHEAD SERVICE AND METER LOCATION
- 5.0 CLEARANCES
- 6.0 OVERHEAD SERVICE ATTACHMENTS AND SERVICE HEADS
- 7.0 U/G SERVICES FROM U/G DISTRIBUTION SYSTEMS
- 8.0 U/G SERVICE FROM O/H DISTRIBUTION SYSTEMS
- 9.0 TERMINATION FACILITIES DETAIL
- 10.0 PERMANENT U/G SERVICE ON A WOOD POST
- 11.0 TRENCHING
- 12.0 REFERENCES

2.0 PURPOSE

The purpose of this standard is to inform customers, engineers, architects and contractors of the requirements for the establishment of overhead or underground electrical service to any new multi-resident, commercial or industrial structure. These requirements have been designed to enable Sierra Pacific Power Company (SPPC) to maintain uniform, safe and reliable service to all customers.

3.0 GENERAL REQUIREMENTS

The type and size of service will depend on customer requirements and available SPPC facilities. *The available type, fault duty and voltage of service should be determined prior to purchase of any service equipment.* For a service of 201 amperes or greater, the customer shall furnish and install a termination/current transformer cabinet and related equipment as specified in SPPC Standard CM0001M, Electric Metering—Commercial and Industrial or a service section as specified in Standard SB0001M, Electric Switchboards 0-600 volts.

The service disconnecting means shall have a minimum rating of 100 amperes. An Underwriter's Laboratories Listed or recognized, heavy duty meter socket is required on all services of 200 amperes. ***Meter by-pass facilities are required as shown in CM0001M.***

Application for electrical service must be made at the local SPPC office prior to bid of project, allowing **as much lead time as possible**, so that arrangements can be made for meter locations, load, voltage and fault duty information can be compiled and any necessary line extension contracts

Sierra Pacific
POWER COMPANY



ENGINEERING & CONSTRUCTION STANDARD

COMMERCIAL / INDUSTRIAL
SERVICES

SHEET 26 OF 88

VOLUME 17

DRAWING NUMBER

CI0001M

| DRAWN | DESIGN | SUPR | DATE | REV |
|-------|--------|------|-------|-----|
| JL | MB | DA | 10/07 | 8 |

prepared and cash advance made prior to actual construction of any utility facilities. All installations must be in compliance with local codes and ordinances effect for the location of services. SPPC rules, regulations and specifications will also apply. Customer installations must be approved by the local 'Building Inspector' in all areas, prior to the connection of service or setting of meter(s).

4.0 OVERHEAD SERVICE AND METER LOCATION

All service drop locations shall be approved by SPPC prior to construction of the service entrance. The location of the point of attachment of the service drop at the building shall be such that it can be reached with a single span, 100 feet (#2 TX)(75'-2/0 TX) maximum from SPPC pole with no overhang of adjacent property and with proper clearances maintained. This point of attachment will be on the building wall or a periscope through the roof facing the nearest SPPC line. When it is impractical to attach service drop below the level of the service head, the termination shall not consist of more than 3 feet of exposed open wire and shall not extend around the corner of the building. A minimum of 18" of service entrance conductor shall be extended out of the service head for the make-up of the required drip loop.

Overhead 3-phase services are limited to 600 amp(208V) and 400 amp(480V) panels with 30' max. of 2 - 4/0 Quadruplex service conductors.

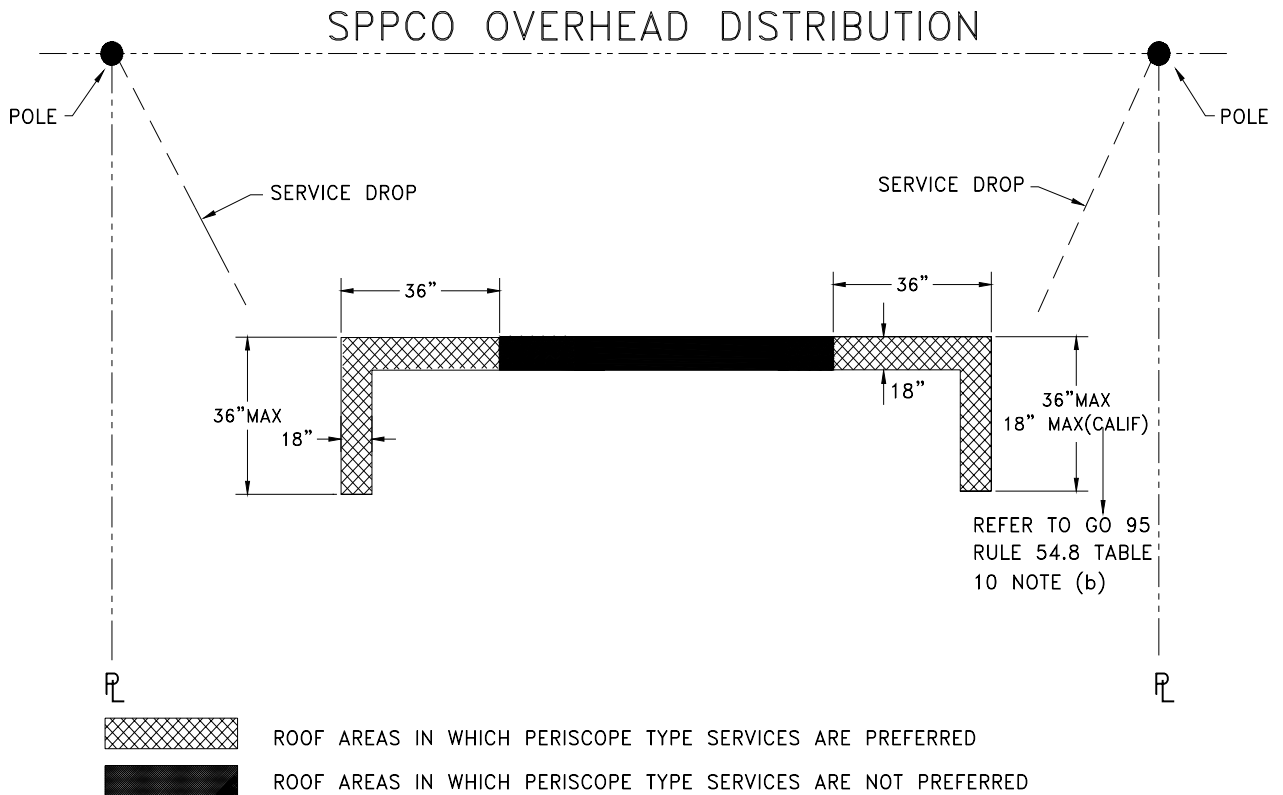

| | | | | |
|-------|--------|------|-------|-----|
| | | | | |
| DRAWN | DESIGN | SUPR | DATE | REV |
| JL | MB | DA | 10/07 | 8 |

ENGINEERING & CONSTRUCTION STANDARD
COMMERCIAL / INDUSTRIAL SERVICES

SHEET 27 OF 88
 VOLUME 17
 DRAWING NUMBER
C10001M

5.0 CLEARANCES

The minimum acceptable clearances for overhead service drops are outlined in the National Electric Code, Article 230-24. Upon request, your SPPC representative will specify a point of attachment which will provide the required clearance of the service wires above thoroughfares and structures and windows, doors, and exits of buildings.

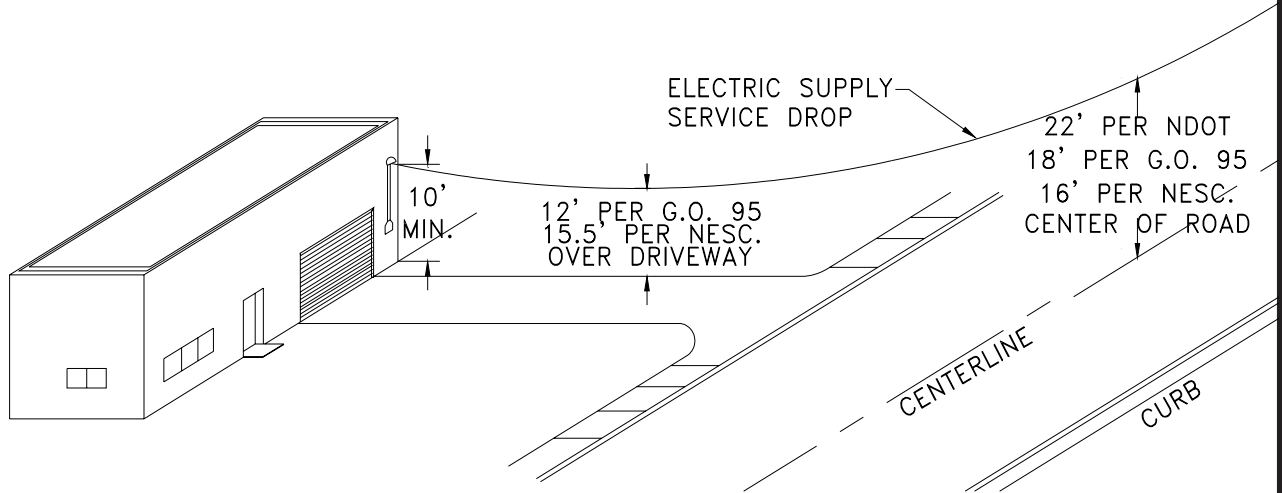

SERVICE DETAILS

ELECTRIC METER SOCKETS MUST HAVE A 36" HORIZONTAL MINIMUM CLEARANCE FROM GAS METERS, RELIEF VENTS

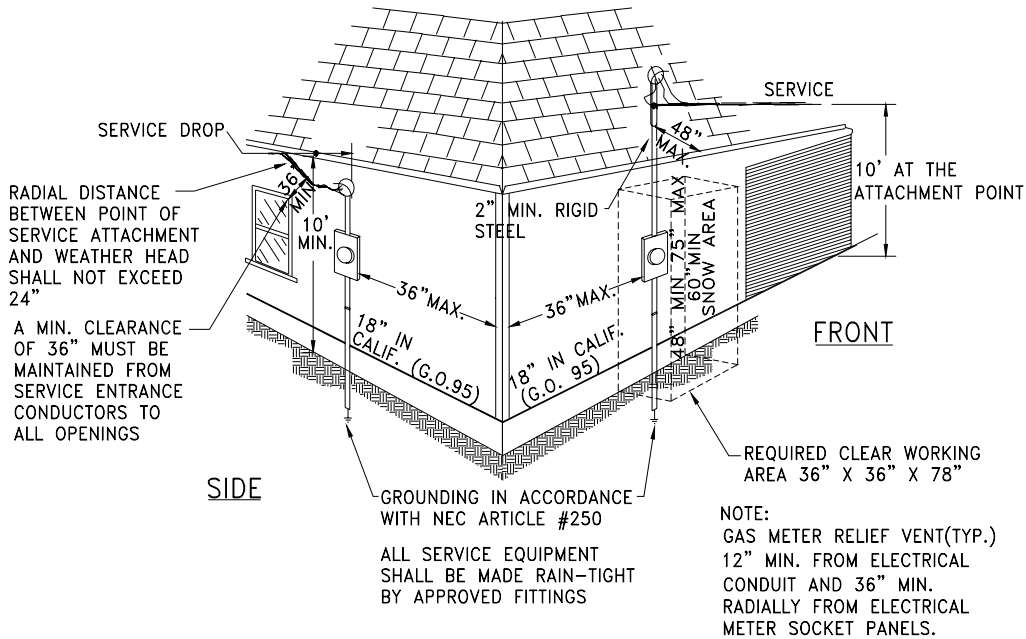

Sierra Pacific
POWER COMPANY



ENGINEERING & CONSTRUCTION STANDARD

COMMERCIAL / INDUSTRIAL
SERVICES

SHEET 28 OF 88

VOLUME 17

DRAWING NUMBER

C10001M

| DRAWN | DESIGN | SUPR | DATE | REV |
|-------|--------|------|-------|-----|
| JL | MB | DA | 10/07 | 8 |

6.0 OVERHEAD SERVICE ATTACHMENTS AND SERVICE HEADS

Two types of service attachments are used by SPPC: service insulators which are attached to the building and periscopes which extend above the roof. Typical methods of attaching low voltage overhead service drops are illustrated in this section. Where the building is high enough to permit proper clearance, the service insulator can be located on roof rafters or wall studs. The customer will provide proper backing for the service insulator (min. 2" x 4"), securely anchored to the building frame. Service insulator will not be attached to roof fascia or wall sheathing, unless proper backing is provided.

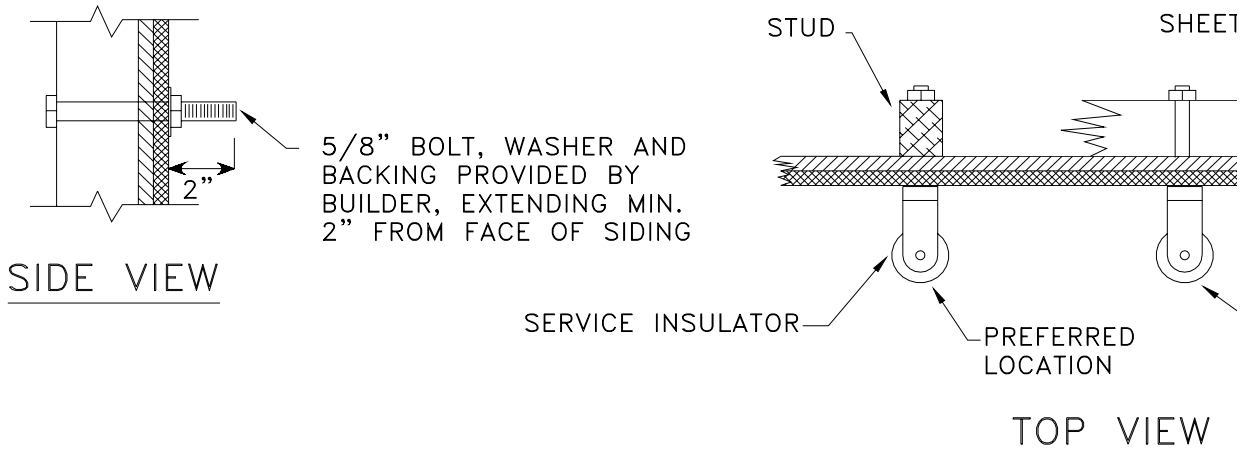

NOTES:

1. **The customer will provide and install the service insulator and attachment.**
2. Service drop shall be attached to the wall facing the nearest SPPC pole line.
3. **All service locations are subject to SPPC approval.** Installation of additional facilities at the customer's expense or future relocation at his expense may be prevented by early consultation with SPPC.
4. If a preferred location is not practicable, consult SPPC in regard to an alternative location.
5. A working space (36" x 36" x 78" high) in front of all meters is required to permit metering installation and provide a safe working environment for SPPC personnel. Any exception from this requirement must be approved by SPPC.
6. For service equipment details, see CM0001M, Electric Metering- Commercial and Industrial.

| | | | | | | | | |
|-------|--------|------|-------|-----|-------------------------------------|--|----------------|--|
| | | | | | ENGINEERING & CONSTRUCTION STANDARD | | SHEET 29 OF 88 | |
| | | | | | COMMERCIAL / INDUSTRIAL SERVICES | | VOLUME 17 | |
| DRAWN | DESIGN | SUPR | DATE | REV | DRAWING NUMBER | | | |
| JL | MB | DA | 10/07 | 8 | C10001M | | | |

A periscope should be used when proper clearances cannot be maintained with a service insulator attachment. **Periscope to be minimum 2" rigid steel or IMC securely fastened to building stud.** Periscope to extend a minimum of 26" above roof.

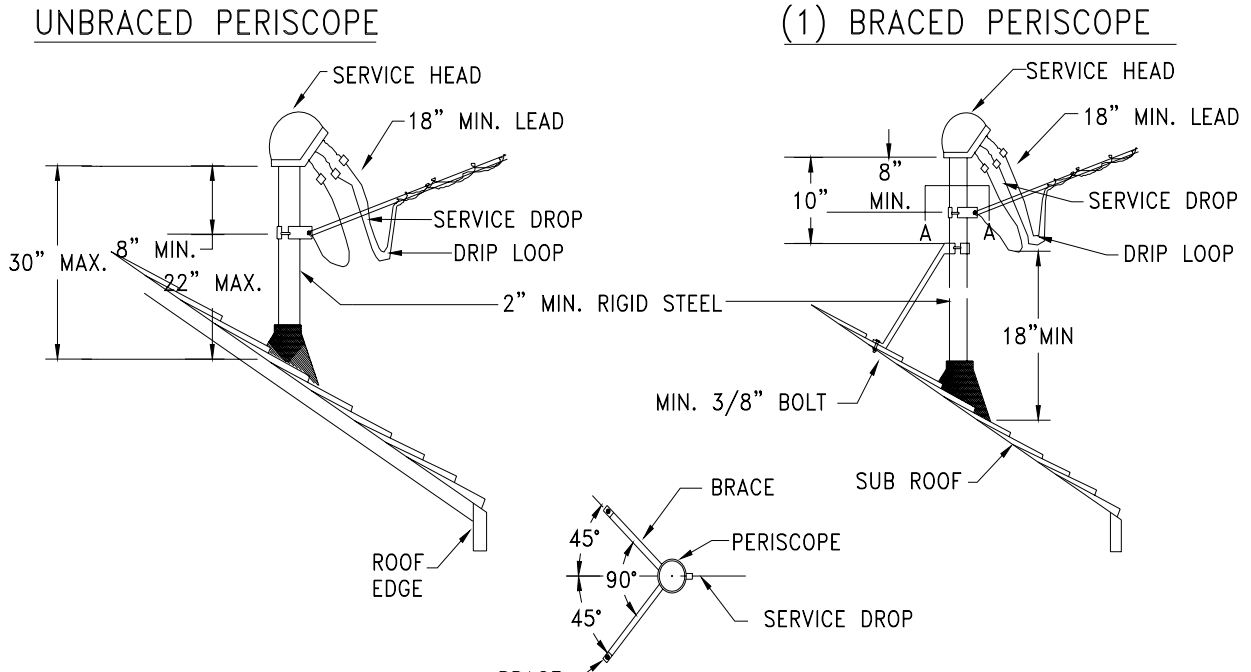

NOTES:

1. Periscope to be installed in accordance with NEC Article #230. Periscope structures projecting over 30" above the roof must be braced against the normal pull (see Section 4.0) of the service drop conductors. *Larger conductor or longer spans may also require bracing.* Bracing, when required, shall consist of two galvanized steel members installed at approximately 90° spread. Minimum size brace shall be 1-1/4" x 1-1/4" x 1/8" galvanized steel angle. Periscope bracing shall be anchored through sub-roof with minimum 3/8" galvanized carriage bolts.
2. **Riser conduit couplings not allowed above the roof.**
3. Service weather head shall not be located on the exterior face of any wall which is less than 2' from any common property line. Point of attachment of service drop must be high enough to meet required clearance. Section 5.0 - Clearances.
4. Where practical, service drops should be attached below the level of service head. The termination point of service drop conductors should not be located more than 24" from service head.
5. Service conductor should extend minimum 18" from service head for the make-up of the required drip loop.
6. Customer to provide and install the service insulator and attachment.

Sierra Pacific
POWER COMPANY

| | | | | |
|-------|--------|------|-------|-----|
| DRAWN | DESIGN | SUPR | DATE | REV |
| JL | MB | DA | 10/07 | 8 |

ENGINEERING & CONSTRUCTION STANDARD
COMMERCIAL / INDUSTRIAL SERVICES

SHEET 30 OF 88
VOLUME 17
DRAWING NUMBER
C10001M

7.0 U/G SERVICES FROM U/G DISTRIBUTION SYSTEM

The customer will be served with an underground service if his site or lot is located within an area that is supplied with existing underground distribution system or if required by local ordinance.

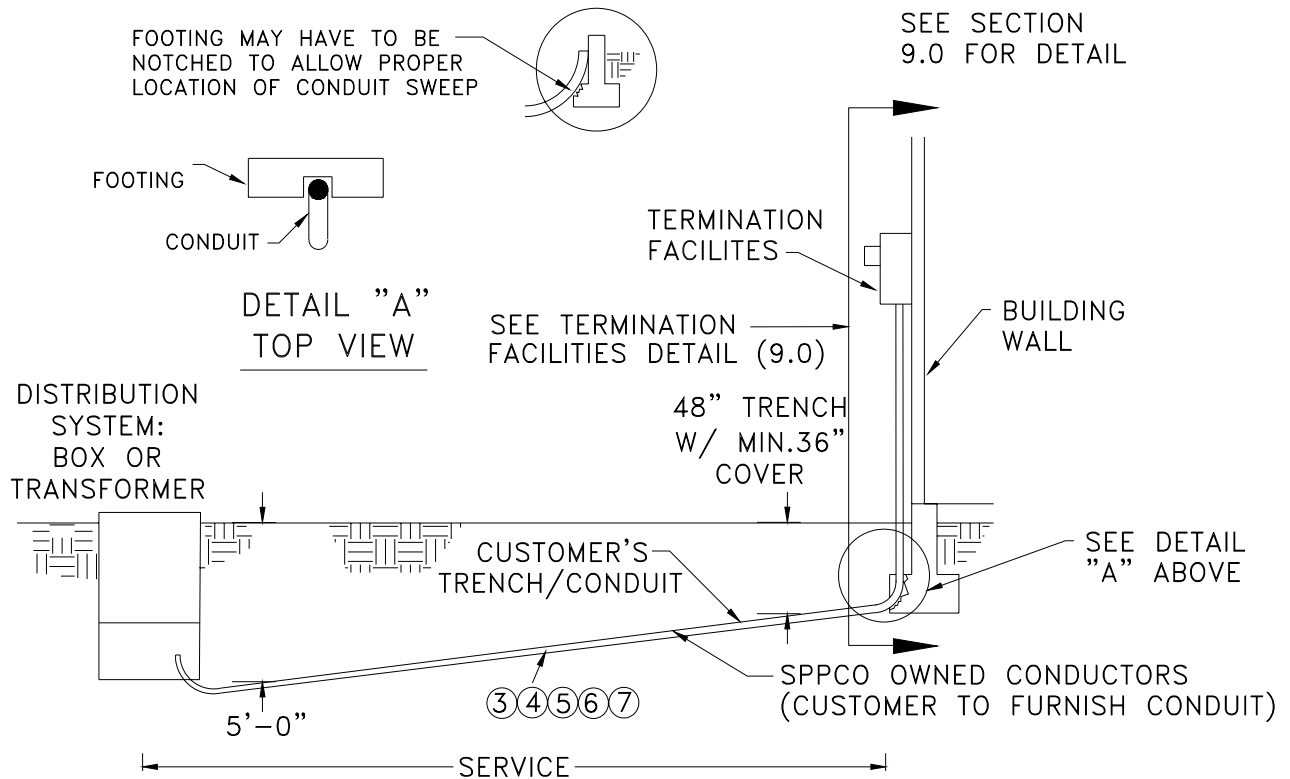

NOTES: (Customer to provide and install)

1. For number/sizing of conduit details, see CB0003U, 600V U/G Cable and Conduit Selection Guide.
2. **Maximum service distance and conduit bends are to be determined by the local customer service planner or inspector.** Generally pull boxes will be required for more than 75' of service or more than 270 degrees of accumulated bends (using five foot sweeps). Contact the local SPPC office for an acceptable layout.
3. U/G conduit must be electrical, gray, PVC (minimum ANSI/ASTM F512, DB-120). **DB-120 conduit can not be exposed.** For more detail see CD0004U, Conduit Application Standard.
4. A 1/4" polyester, pull line with sequential footage markings and minimum breaking strength of 400 pounds to be installed in each conduit by customer at time of conduit installation.
5. **Services should be no longer than 60'** from transformers or additional conduits/cable runs may be required, see CB0003U.
6. Commercial/Industrial Services greater than 2001 amps will be installed in cable trench, see GI0011U, Cable Trench Installation Guide.

Sierra Pacific
POWER COMPANY



ENGINEERING & CONSTRUCTION STANDARD

COMMERCIAL / INDUSTRIAL
SERVICES

SHEET 31 OF 88

VOLUME 17

DRAWING NUMBER
C10001M

| DRAWN | DESIGN | SUPR | DATE | REV |
|-------|--------|------|-------|-----|
| JL | MB | DA | 10/07 | 8 |

8.0 U/G SERVICE FROM O/H DISTRIBUTION SYSTEM

If the customer is located in an area served by an overhead system and prefers to have the service installed underground, or if the local ordinance requires underground service, the service may be provided by means of a riser installed on an existing pole. This service arrangement is limited to 1-4" riser conduit, (600 amp service max.) consult SPPC for details. The customer should contact his local SPPC office for trench and riser pole locations.

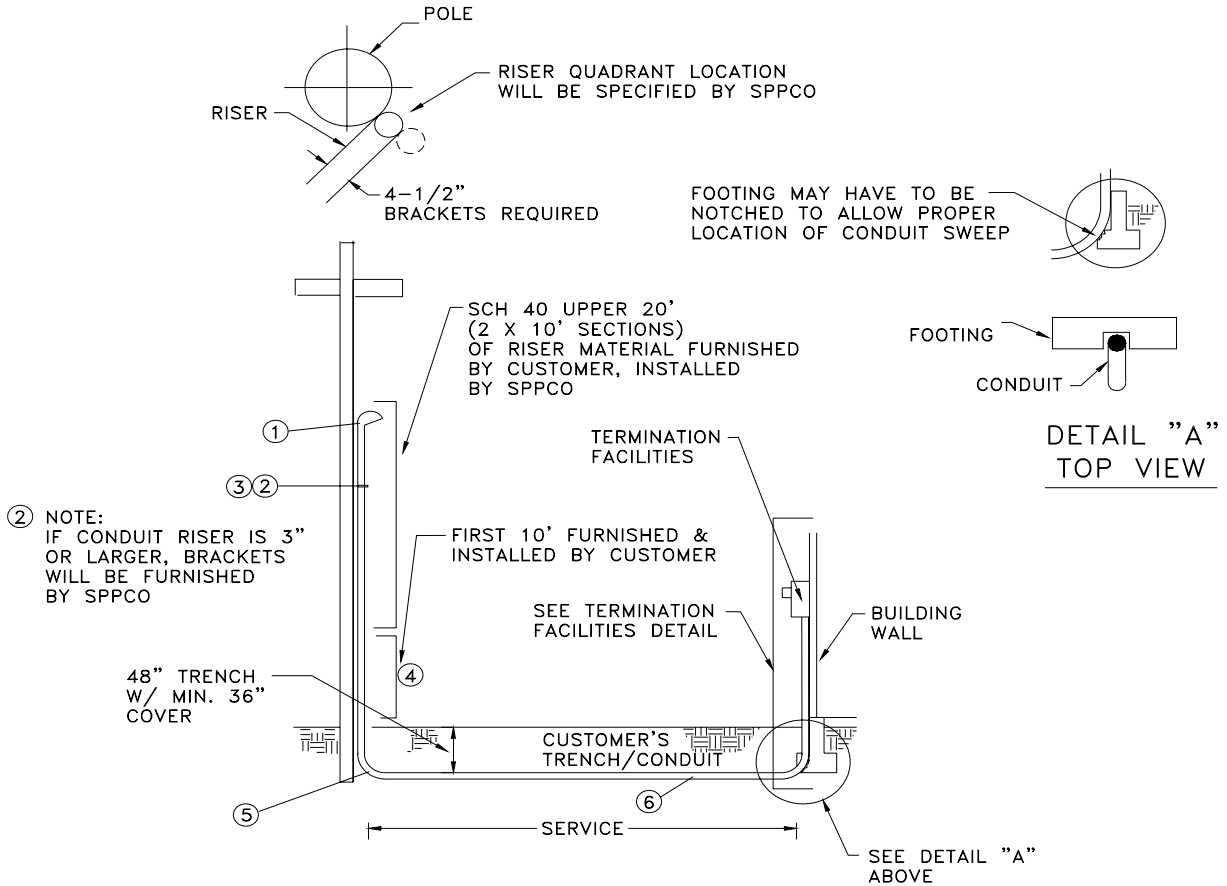

NOTES: (Customer to provide and install).

1. Weatherhead.
2. Steel conduit not allowed in upper section.
3. Minimum Schedule 40 PVC electrical, gray, conduit. Straps every 30". If conduit riser is 3" or larger, *standoff brackets to be provided and installed by SPPC.*
4. Rigid steel, or Schedule 80 PVC electrical, gray, conduit for first 10' above ground.
5. Minimum 36" radius sweep. **Sweep material to match first section of riser material (pvc to pvc, steel to steel).**
6. Minimum ANSI/ASTM F512, DB-120 electrical, gray, conduit w/a 1/4" polyester, pull line with sequential footage markings and minimum breaking strength of 400 pounds to be installed by customer. **NOTE: DB-120 conduit cannot be exposed.**

9.0 TERMINATION FACILITIES DETAIL

For detailed meter equipment requirements, see CM0001M, Electric Metering—Commercial-Industrial.

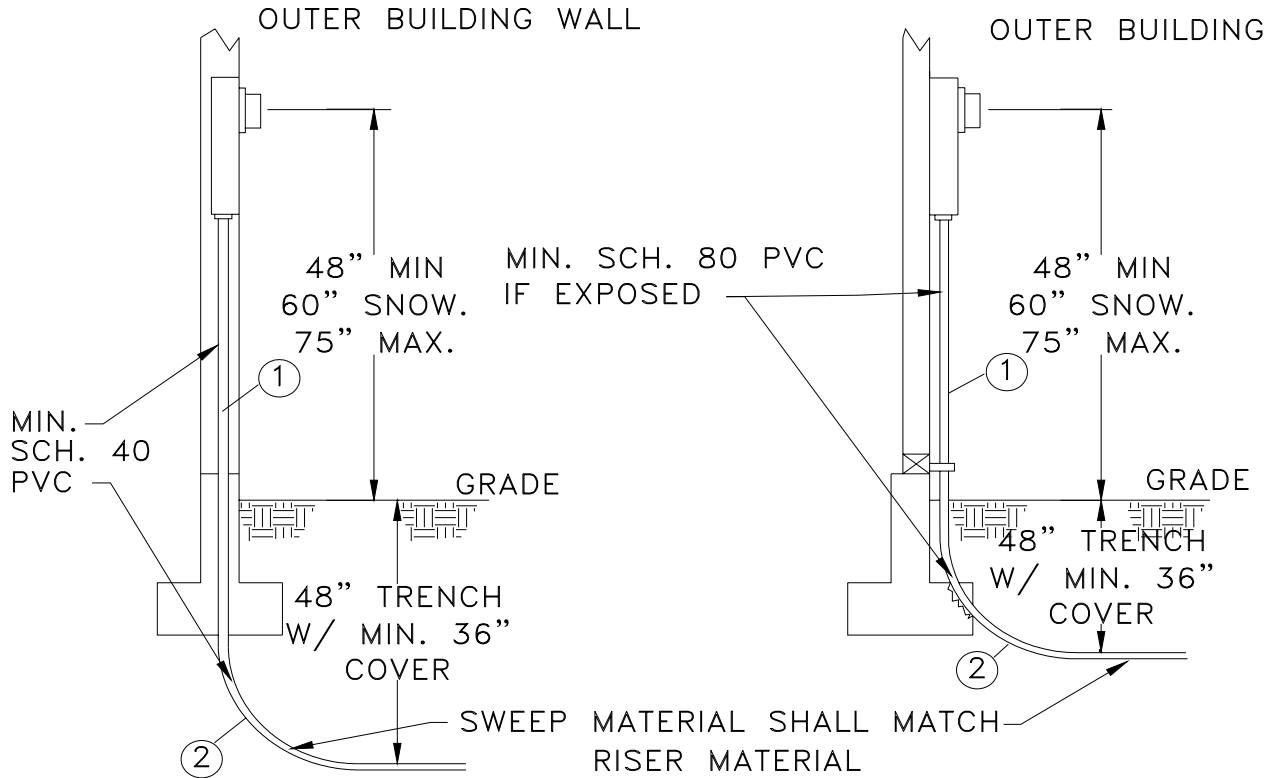

NOTES: (Customer to provide and install)

1. Conduit riser shall be minimum Schedule 40 PVC electrical conduit (gray) if recessed or minimum Schedule 80 PVC electrical, gray, conduit if exposed. For further details, see CD0004U, Conduit Application Guide.
2. Conduit sweep material must be the same as riser material and have minimum 36" radius.
3. The socket and enclosure of termination point shall be specifically designed to receive service cable from underground source.
4. A working space (36" x 36" x 78" high) in front of all meters is required to permit metering installation and provide a safe working environment for personnel.
5. **The meter location will have an assigned address.**

Sierra Pacific
POWER COMPANY

ENGINEERING & CONSTRUCTION STANDARD
COMMERCIAL / INDUSTRIAL
SERVICES

SHEET 33 OF 88

VOLUME 17

DRAWING NUMBER
CI0001M

| DRAWN | DESIGN | SUPR | DATE | REV |
|-------|--------|------|-------|-----|
| JL | MB | DA | 10/07 | 8 |

10.0 PERMANENT U/G SERVICE FROM WOOD POST

Approved manufactured steel pedestals are preferred construction but a terminating facility limited to a maximum of 200 amps self-contained meter panel attached to a 6" x 6" x 10' full length 'treated wood' or redwood post is acceptable.

Post/pedestal installations shall be in locations out of the way of any vehicular traffic.

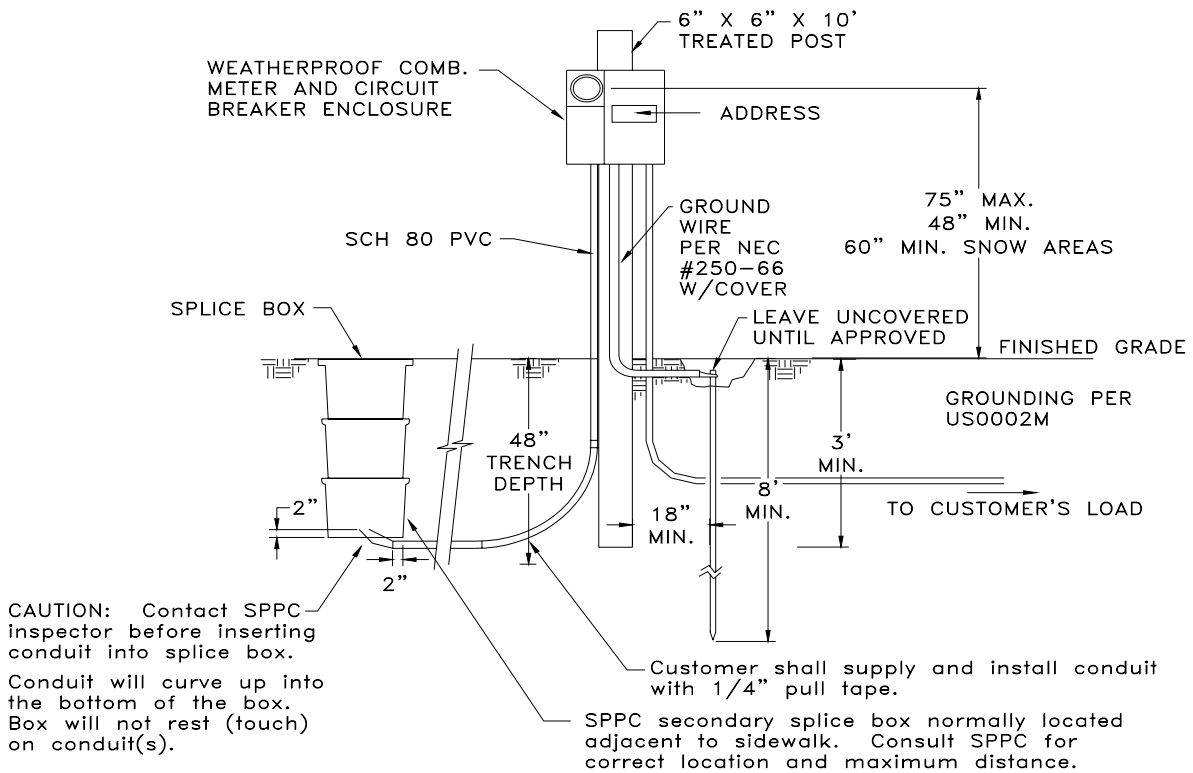

11.0 TRENCHING

11.1 Commercial/Industrial services will typically be multiple 4" conduits up to and including 2000 Amps. **For 2001 Amp or larger panels**, cable trench is required, refer to GI0011U, Vol. 17, Section 7, for details.

11.2 Trenching configurations are subject to change due to location and joint utility requirements. Check with local SPPC office if questions arise.

11.3 Trenching and backfill must conform to SPPC Standards TE0001U and SUB01X, Vol. 17.

Sierra Pacific
POWER COMPANY

ENGINEERING & CONSTRUCTION STANDARD

COMMERCIAL / INDUSTRIAL
SERVICES

SHEET 34 OF 88

VOLUME 17

DRAWING NUMBER

CI0001M

| DRAWN | DESIGN | SUPR | DATE | REV |
|-------|--------|------|-------|-----|
| JL | MB | DA | 10/07 | 8 |

11.4 The electric underground service may be installed with joint utilities (gas, telephone, cable television). **The electric service will maintain a minimum 12" separation from other utilities.** See appropriate utility representative for joint trench details.
 (For SPPC joint trench details, see TE0001U.)

12.0 REFERENCES

Electric Metering - Commercial and Industrial, CM0001M, Vol. 17, Section 8.
 Electric Switchboards 0-600 Volts, SB00011M, Vol. 17, Section 8.
 600V Underground Cable and Conduit Selection Guide, CB0003U, Vol. 17, Section 4.
 Conduit Application Standard, CD0004U, Vol. 17, Section 4.
 Backfill Material Specifications, SUB01X, Vol. 17, Section 3.
 Trenching Excavation Standards, TE0001U, Vol. 17, Section 3.

| | | | | | | | |
|---|--------|------|-------|-----|---|--|------------------------------|
|  | | | | | ENGINEERING & CONSTRUCTION STANDARD | | SHEET <u>35</u> OF <u>88</u> |
| | | | | | COMMERCIAL / INDUSTRIAL SERVICES | | VOLUME <u>17</u> |
| DRAWN | DESIGN | SUPR | DATE | REV | DRAWING NUMBER <i>CI0001M</i> | | |
| JL | MB | DA | 10/07 | 8 | | | |