

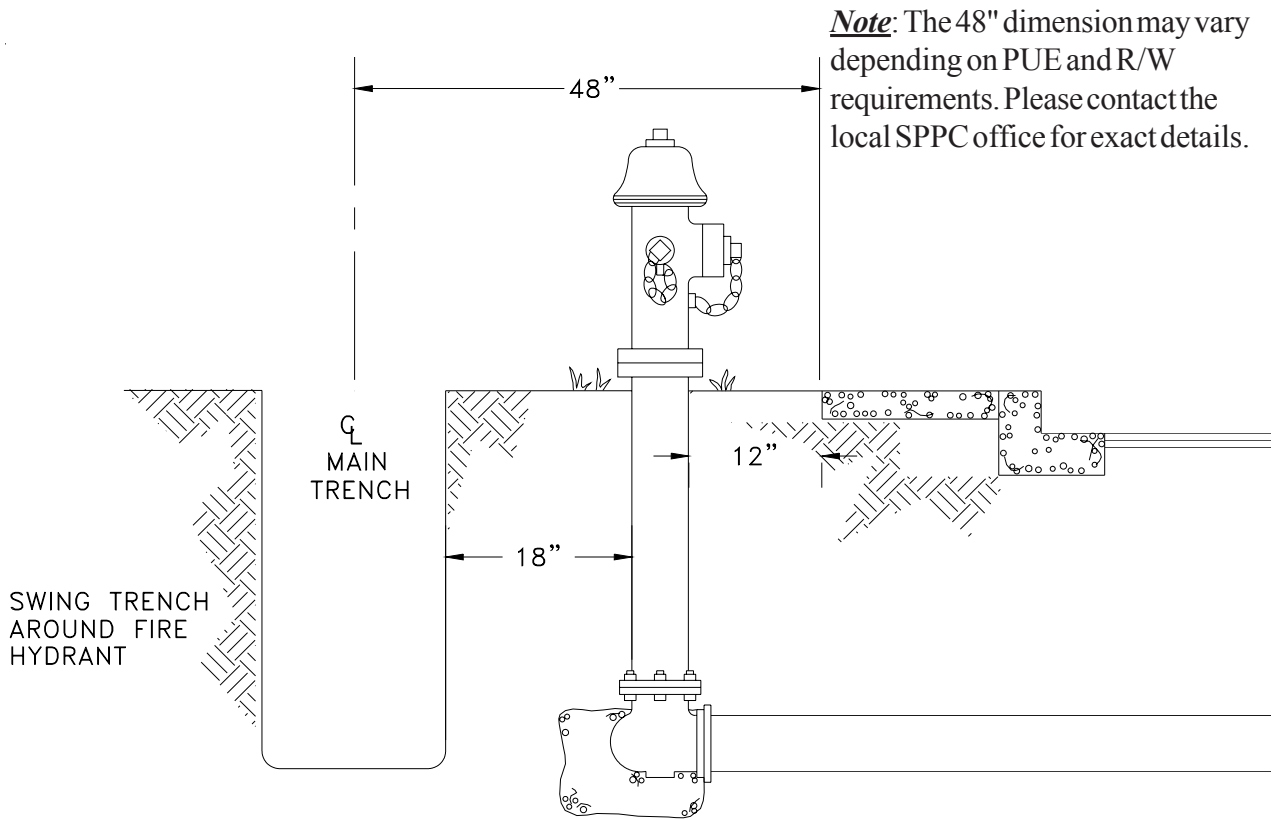

# ELECTRIC TRENCH / HYDRANT BYPASS DETAIL

## EXCEPTION SHOWN

**GENERALLY, HYDRANTS WILL BE LOCATED ON OPPOSITE  
SIDE OF STREET FROM ELECTRIC MAIN TRENCH.**



				
DRAWN	DESIGN	SUPR	DATE	REV
JL	MB	DA	5/05	6

**ENGINEERING & CONSTRUCTION STANDARD**

## ELECTRIC TRENCH HYDRANT BYPASS DETAIL

SHEET **49** OF **50**

VOLUME **17**

DRAWING NUMBER  
**TE0045U**

**THIS PAGE LEFT  
INTENTIONALLY BLANK**

**Sierra Pacific**  
POWER COMPANY



**ENGINEERING & CONSTRUCTION STANDARD**

**SHEET 50 OF 50**

**ELECTRIC TRENCH  
HYDRANT BYPASS  
DETAIL**

**VOLUME 17**

**DRAWING NUMBER  
*TE0045U***

DRAWN	DESIGN	SUPR	DATE	REV
JL	MB	DA	5/05	6