

# DESIGN GUIDE FOR CUSTOMER-OWNED TRANSFORMER VAULTS

## 1.0 INDEX

- 1.0 INDEX
- 2.0 PURPOSE
- 3.0 GENERAL
- 4.0 LOCATION OF INSTALLATION
- 5.0 VENTILATION
- 6.0 VAULTS IN STREETS AND RIGHTS-OF-WAY
- 7.0 CUSTOMER BUILDING VAULTS
- 8.0 SECONDARY TERMINATION AT TRANSFORMERS
- 9.0 METERING
- 10.0 REFERENCES
- 11.0 VAULT DETAILS/DRAWINGS

## 2.0 PURPOSE

This standard represents SPPC's basic design criterion for customer-owned transformer vaults. **Customer owned vaults must follow NEC Article 450-C.**

## 3.0 GENERAL

The requirements in this standard may be in addition to the requirements in NEC, and all Local Codes. The customer is responsible for providing a complete vault structure.

Vaults may be either installed underground, with access and ventilation through an opening in the top section, furnished by the customer within his premises, or as an attachment with access through a door in one of the vault walls and/or a hatch in the roof of the vault.

## 4.0 LOCATION OF INSTALLATION

- 4.1 When furnished by the customer and installed on his premises, the vault must be so located as to be accessible at all times by SPPC crews and hoisting equipment. Future expansion plans by the customer must not affect accessibility. Customer shall furnish dimensioned plan and elevation views of the entire project showing the vault location in relation to surrounding structural parts. **Two sets of drawings clearly showing the vault must be submitted to the appropriate SPPC Customer Services Engineering Dept. (for Reno, MC: R77CSE), P.O. Box 10100, Reno Nevada**

					ENGINEERING & CONSTRUCTION STANDARD		SHEET <u>35</u> OF <u>46</u>	
					DESIGN GUIDE FOR CUSTOMER OWNED TRANSFORMER VAULTS		VOLUME <u>17</u>	
							DRAWING NUMBER <b><i>VB0100U</i></b>	
DRAWN	DESIGN	SUPR	DATE	REV				
JL	MB	DA	07/05	4				

**89520, and for districts outside of Reno, submit to your local district office.** The elevational view will be checked for vault elevation and its ventilating system in relation to the levels of streets, water mains, sewer lines, storm-drains, and other discharge facilities that, when ruptured or overflowing, could flood the vault. No such piping is permitted to enter or pass through a transformer vault (NEC 450-47).

- 4.2 Vaults shall be located where they can be ventilated to the outside air whenever practicable (NEC 450-41).
- 4.3 Underground vaults with openings at or below street level must be considered as subject to flooding. A means to eliminate or reduce the degree of flooding is to raise the vault's top section above its surroundings where possible on customer's property.

## **5.0 VENTILATION**

5.1 The vault can be provided with ventilation directly to the outside air of total net area as shown below in 5.2. Ventilation may be incorporated into the design of the door, cover, hatches, etc. Net area means after deducting area taken by grates, mesh, louvers, etc. Vault ambient temperatures shall not exceed 40°C and the average ambient temperature for any 24 hour period shall not exceed 30°C. Forced ventilation thermostatically controlled (5.3) can be utilized if necessary and approved by SPPC. Forced air inlets shall be near the floor and exhaust near the ceiling of the vault. Both inlet and exhaust ducts shall be fire proofed including fire dampers.

5.2 Natural Air Circulation: The size of opening is determined by NEC Article 450-45(c) as follows: **Net Area** in square inches  $\geq 3 \times \text{kVA rating}$ .

Example:

For a 50 kVA transformer, net ventilation area =  $3 \times 50 = 150$  sq. in.

**Note:** 1 sq. ft. is the minimum net area also for any transformer under 50 kVA. When determining the size of the opening, all obstructions, such as the grate, must be added to the net area. Two openings at opposite vault ends are more effective than one center opening of the same total net area.

5.3 Forced Air Circulation:

- A. The accurate calculation of the minimum required quality of cooling air, expressed in cubic-foot per minute (CFM), should be made. The flow of the air must be such that the transformer is cooled.
- B. Air inlets and outlets shall be located at opposite ends of the vault, the inlet positioned as close to the floor as possible (maximum of 18"), and the outlet as close as possible to the roof of the vault. The farther apart inlet and outlet are from each other within the given vault space, the more efficient the cooling of the transformer(s) within it.



DRAWN	DESIGN	SUPR	DATE	REV
JL	MB	DA	07/05	4

- C. Transformer data for loss calculations will be 1.15% of nameplate for transformers less than 750kva; 0.87% for 750/1000/1500 kva transformers and 0.77% for transformers greater than 1500 kva.
- D. Use 0.045 kw per 10 ft<sup>2</sup> for heat transferred through the vault walls and roof, if not exposed to the sun.
- E. The volume of cooling air per minute will be calculated as follows:
  1. CFM = 110CFM/KW net loss.
  2. Net Loss KW = transformer losses minus vault heat transfers.
- F. Fans will be less than 1750 RPM to reduce noise. Axial type fans capable of continuous service are recommended. All fans require a manual "across the line" starter and "overload" protection.
- G. In vaults where continuous heavy loading does not occur, thermostatic control of the fan may provide economic advantages by reducing power requirements and fan maintenance. Thermostats will generally be set @85°F with a differential of 15°F.

## 6.0 VAULTS IN STREET AND RIGHTS-OF-WAY

- 6.1 Vaults of this type are usually precast, selected from manufacturer's catalogs, and installed by the customer or in some cases by SPPC The following rules apply:
- A. Opening(s) in the top section shall be large enough to install and remove transformer(s) in their upright position with only the cover section of the vault removed and without disturbing the pavement that extends over the remainder of the vault.
  - B. The cover section(s) will have an opening covered by a grate to permit adequate ventilation. All ventilation openings shall be covered with durable gratings, screens, or louvers according to the treatment required in order to avoid unsafe conditions.
  - C. Transformers and equipment in underground vaults shall be submersible or partially submersible as the case may permit.
  - D. Vaults containing more than 100 kVA transformer capacity shall be provided with a sump in the lowest part of the floor.
  - E. Ground rods, minimum of (2) 5/8" x 8', to be installed in the trench near opposite corners of the vault. Grounding bus will be connected to the rods (grd inserts) and will be continuous around the inside of the vault, consisting of #2/0 str copper (min.). Aluminum not permitted.

## 7.0 CUSTOMER BUILDING VAULTS

- 7.1 The vault must conform to drawing on sheet 43 of this standard. The no-scale outline on that drawing must be supplemented by a scaled drawing showing all installations in their true relationship per 4.1.

					ENGINEERING & CONSTRUCTION STANDARD		SHEET <u>37</u> OF 46	
					<b>DESIGN GUIDE FOR CUSTOMER OWNED TRANSFORMER VAULTS</b>			
DRAWN	DESIGN	SUPR	DATE	REV				
JL	MB	DA	07/05	4	<b>VB0100U</b>			

- 7.2 Pulling irons are to be rated at least 20,000 lbs. working load. Two or more on each wall, (if more than 2 transformers, 1 for each transformer), 24 inches from the wall, the location to be determined by SPPC Customer Services Engineering. Each pulling iron must be tied into the rebar in the wall and located approximately 18" above the floor. One iron will be provided for cable pulling located in opposite wall, same height as incoming primary conduits.
- 7.3 The walls and roof of vaults shall be constructed of materials which have adequate structural strength for the conditions with a minimum fire resistance of three hours. The floors of vaults in contact with the earth shall be of concrete not less than 4 inches thick, but when the vault is constructed with a vacant space or other stories below it, the floor shall have adequate structural strength for the loading imposed thereon (25,000 lbs for a 2500 kva) and a minimum fire resistance of three hours. The three - hour fire resistance requirement may be reduced to one hour fire resistance if transformers are protected with automatic carbon dioxide or halon systems. (NEC 450-42).
- 7.4 For doorways. See NEC 450-43.  
Floor and bottom four inches of wall and doorway openings to be constructed and sealed so as to contain any oil spill. Each doorway leading into a vault from the building interior shall be provided with a tight - fitting door having a minimum **fire rating of three hours**. *The vault shall have at least two means of entrance/exit.* The doors shall swing out and be equipped with locks and hinges/latches that permit opening by easy pressure or torque on the operating components. Door will be provided with a SPPC key box.
- 7.5 If the customer cannot guarantee that the vault is safe from entry of water, all equipment must be at least partially submersible and installations such as electrical outlets and lights must be vapor tight. (NEC 450-46).
- 7.6 Vault floors shall slope to a sump of 12" diameter, (or one (1) foot square), with 12" minimum depth. A grated cover will be required.
- 7.7 The customer must provide a continuous grounding bus ring consisting of a minimum of #2/0 str copper wire and shall be tied to the structural steel of the building at two or more points and be run around the inside walls of the vault at 12" above the floor. Grounding connections shall be cadweld or equivalent. The grounding bus will be used for equipment grounding. Aluminum is not permitted (NEC 250-92(a)).
- 7.8 Vault lighting and wall outlets will be provided by the customer and shall be connected to the customer's emergency power supply when applicable. As a rule, lighting, approximately 2 watts per square foot (25 foot candles) of floor space, shall be provided from at least two



DRAWN	DESIGN	SUPR	DATE	REV
JL	MB	DA	07/05	4

overhead fixtures with a control switch mounted close to the personnel access entrance into the vault. 120V wall outlets consisting of duplex receptacles, minimum rating 20 amps, shall be provided so that no point on a wall is more than ten feet away from an outlet.

- 7.9 Primary cables will not be laid on the vault floor. Wall racking or ceiling supports will be provided by the customer. Any support structures shall be constructed such that a minimum of 9' of clearance exists from the bottom of the cable rack to the vault floor. Any metal racking will be bonded to the vault ground system. (NEC 450-10).
- 7.10 Any pipe or duct system foreign to the electrical installation shall not enter or pass through a transformer vault. Piping or other facilities provided for fire protection, or for transformer operation shall not be considered foreign to the electrical system. (NEC 450-47).
- 7.11 Transformer vault area shall not be used for storage. NEC 450-48.
- 7.12 A telephone is required to be installed in the vault room. This requirement does not apply to outside underground vaults where access to a radio is available. (
- 7.13 No customer equipment is allowed in the transformer vault area with the exception of his secondary bus. The bus shall be designed and located such that it will not block the primary cable installation.
- 7.14 Each vault, through the roof access, must have a permanently attached ladder. A light switch must be near the top of the ladder. The ladder must be installed so as not to interfere with vault's equipment opening.

## **8.0 SECONDARY TERMINATION AT TRANSFORMERS**

- 8.1 The customer shall provide a secondary cable support system. Any metal racking will be bonded to the vault ground system. The support system shall be arranged to provide a maximum unobstructed passageway for personnel.
- 8.2 For the installation of the bus duct, see SPPC Standard SB0001M, in Section 8.
- 8.3 The bus duct will be terminated to the transformer using an 18" or 24" flexible copper braid connector rated at 1000 amps each. SPPC stock #25-2802/25-2804.
- 8.4 For general information see Drawings on Sheets 43 & 44 of this Standard.

## 9.0 METERING

The customer's main switch and metering panel shall be located outside of and adjacent to the vault. Space at the metering panel shall be provided for the meter(s) and metering instrument transformers which SPPC shall provide. Metering equipment and switchgear must be approved by SPPC metering dept. prior to installation.

## 10.0 REFERENCES

- 10.1 SPPC Engineering and Construction Standard: Volume 5, DES 05U, "Large Under ground Commercial Distribution Service Planning Guide".
- 10.2 SPPC: TRS10X "Three- Phase Subway/Vault - Type Distribution Transformer Specification".
- 10.3 National Electrical Code (NEC): Articles 250 and 450.
- 10.4 ASTM Standard E119-75 "Construction Materials for 3 - Hour Fire Resistance".
- 10.5 NFPA 251: "Fire Tests of Building Construction and Materials".
- 10.6 NFPA 80 (ANSI): Standard for the Installation of Fire Doors and Windows".
- 10.7 ANSI 42.1: "Methods of Fire Tests of Building and Materials".
- 10.8 ANSI/UL 555: "Standard for Fire Dampers".
- 10.9 California Administrative Code: Title 8 "Industrial Relations".

**Sierra Pacific**  
POWER COMPANY



ENGINEERING & CONSTRUCTION STANDARD

SHEET 40 OF 46

**DESIGN GUIDE FOR  
CUSTOMER OWNED  
TRANSFORMER VAULTS**

VOLUME 17

DRAWING NUMBER  
**VB0100U**

DRAWN	DESIGN	SUPR	DATE	REV
JL	MB	DA	07/05	4

# 11.0 VAULT DETAILS/DRAWINGS

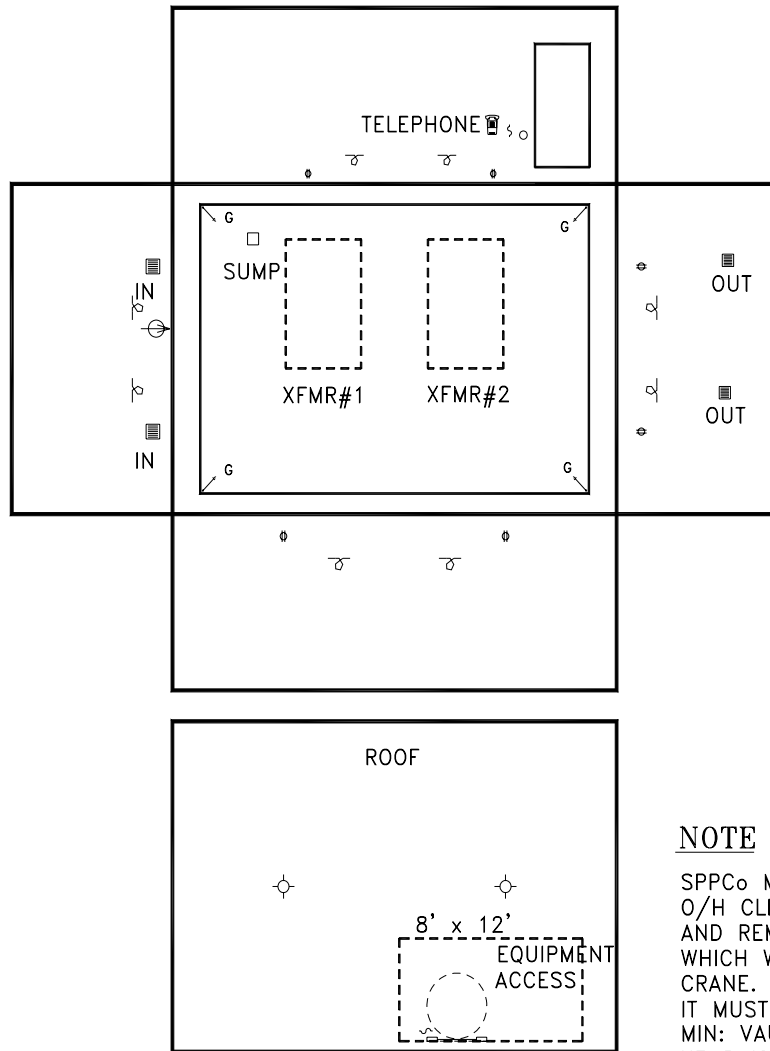

TOP VIEW  
SHOWING WALLS

**NOTE**

SPPCO MUST HAVE 16' TO 20' O/H CLEARANCE FOR INSTALLING AND REMOVING SPPCO EQUIPMENT WHICH WILL REQUIRE AN O/H CRANE. IF OVERHANG IS PROVIDED IT MUST BE REMOVABLE.  
MIN: VAULT SIZE FOR 2-2500 kVA XFMR IS 25' X 25' X 15'HT

**LEGEND**

- |     |   |   |   |
|-----|---|---|---|
| ⌋   | 1. RECESSED PULLING IRONS (MIN. 2 PER WALL) | ⌋ | 9. OVERHEAD LIGHT SWITCH (3 WAY)                                    |
| □   | 2. SUMP-GRATED 12"X 12"X 12" (MINIMUM)      | ⌈ | 10. TRANSFORMER   |
| ⌈   | 3. DOOR-METAL WITH 4" SILL (MIN.)           | ▣ | 11. LOUVERS (FIRE DAMPER)   |
| —   | 4. GROUNDS (2 MINIMUM) / GROUND BUSS.       | □ | 12. SPPCO KEY LATCH ASSEMBLY CUSTOMER (OUTSIDE OF VAULT/METER ROOM) |
| ⌈EA | 5. EQUIPMENT ACCESS (3 PIECE: 4' X 8')      | ☎ | 13. TELEPHONE-WALL MOUNTED  |
| ⊙   | 6. GRATING COVER (39")                      | ⊕ | 14. FORCED AIR VENT   |
| ⊕   | 7. 120 VOLT OUTLET                          | — | 15. LADDER  |
| ⊙   | 8. OVERHEAD LIGHT (150 WATT) VAPORTIGHT     |   |   |

					<b>ENGINEERING &amp; CONSTRUCTION STANDARD</b>		SHEET <b>41</b> OF <b>46</b>	
<b>DESIGN GUIDE FOR CUSTOMER OWNED TRANSFORMER VAULTS</b>					VOLUME <b>17</b>		DRAWING NUMBER <b>VB0100U</b>	
DRAWN	DESIGN	SUPR	DATE	REV				
JL	MB	DA	07/05	4				

## CONSTRUCTION NOTES

A. Be sure adequate concentric neutral wire is provided for proper operation of separable connectors.

B. Underground Cable identification tags to be used in accordance with CAB07U, Volume 5 and Volume 19, Operating procedures Section 21.

C. Fault indicators to be used in accordance with HDE02U, Volume 5.

D. Energized cables to be handled in accordance with Volume 19, Underground Operating Procedures, Section 20.

## CUSTOMER NOTES

1. Customer is responsible for secondary buss duct and primary cable trays.
2. Contact appropriate SPPC Planner for precise transformer measurements.
3. Dimensions shown are for 25KV 2500 KVA transformer.
4. Buss duct will terminate with NEMA standard spacing (4 hole) see SB0001M.

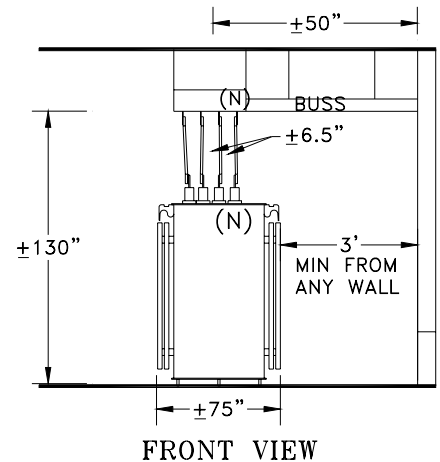
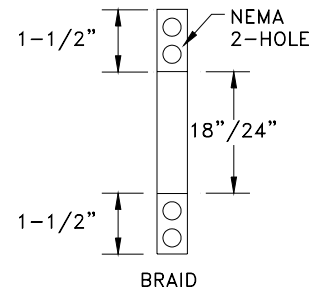
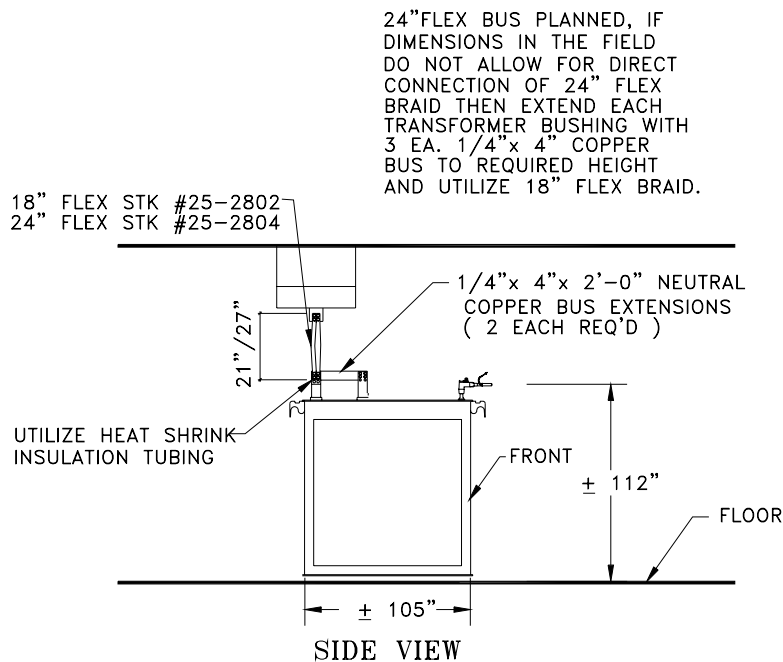

EXAMPLE ONLY

**Sierra Pacific**  
POWER COMPANY



ENGINEERING & CONSTRUCTION STANDARD

SHEET 42 OF 46

**DESIGN GUIDE FOR  
CUSTOMER OWNED  
TRANSFORMER VAULTS**

VOLUME 17

DRAWING NUMBER  
**VB0100U**

DRAWN	DESIGN	SUPR	DATE	REV
JL	MB	DA	07/05	4