

NOTES:

- 1) TRACER WIRE, STOCK ITEM #45-7500, TO BE INSTALLED PER THE GAS CONSTRUCTION SPECIFICATIONS.
- 2) ALL WIRE SPLICES TO BE MADE USING A SPLIT BOLT CONNECTOR WRAPPED WITH AQUA-SEAL AND ELECTRICAL TAPE.

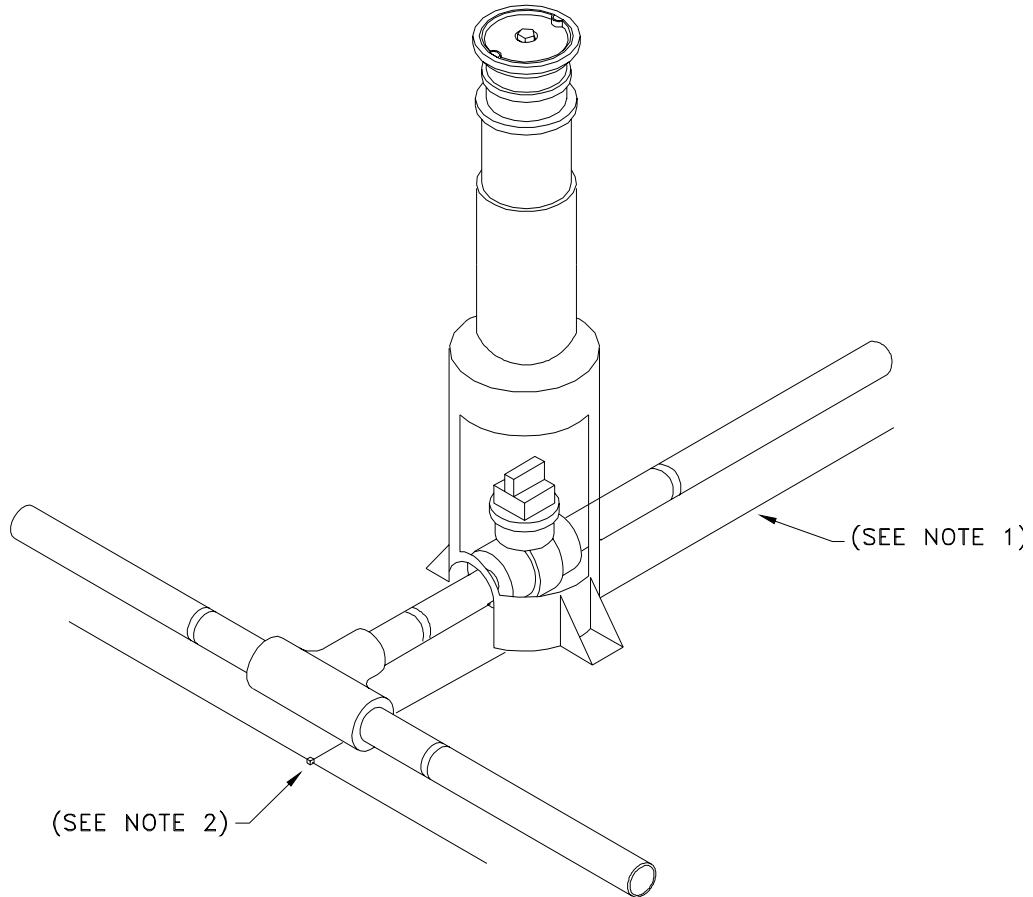

MATERIAL LIST

STOCK #	QTY.	DESCRIPTION
45-2231	1.0	TEE 6" IPS BUTT FUSION PE3408
43-2042	1.0	VALVE 6" PE3408
43-0025	1.0	BOX 6" PE VALVES TRAFFIC RATED H-20
19-1670	1.0	CONN SPLIT BOLT COPPER MAX #10 STR



ENGINEERING & CONSTRUCTION STANDARD

SECTION 5 GAS CONSTRUCTION DRAWINGS
DISTRIBUTION BRANCH INSTALLATIONS
6" PE RUN X 6" PE BRANCH

SHEET 7 OF 16

DRAWING NUMBER

DBI06G

DRAWN	DESIGN	SUPR	DATE	REV
KS	KS	HB	5/98	7/06