

Electric Service Requirements

1. Purpose

The purpose of this standard is to assist the customer in planning for an acceptable location and type of termination for overhead service from the NVE overhead electric distribution system.

2. Table of Contents

1.	Purpose	1
2.	Table of Contents	1
3.	Limits	1
4.	Customer Responsibility	1
5.	NVE Responsibility	1
6.	Service and Meter Location.....	1
7.	Clearances.....	3
8.	Service Attachments And Weather Heads.....	4

3. Limits

The requirements of this standard are limited to single or multiple dwelling residences with a 400a maximum single phase entrance. If the length of service is such that it would prove electrically prohibitive, a transformer and primary extension may be required, in which case, NVE's overhead line extension rule will be applied. NVE will install a single span of service drop from its pole to the customer's permanent approved support, provided the customer has made a bona fide application for service and NVE's distribution-pole line is located on the customer's premises or in an easement (public or private) adjoining said premises.

4. Customer Responsibility

The customer shall furnish, install and maintain, at his expense, the riser conduit, service entrance conductor, weather head, service equipment and grounding in accordance with local, state and national codes.

See 2.2GN05 (Standards Volume 1) for generator transfer switch requirements.

5. NVE Responsibility

NVE will furnish, install and maintain the service drop conductors, connectors to service entrance conductors and any meters. Service and Meter Location

				Electric Service Requirements		RR-2
				Overhead Electric Service: Residential		
Drawn:	Eng:	Appr:	Date:			Revision: 1
DH	DH	MES	2/08			Page 1 of 4

Electric Service Requirements

6. Service and Meter Location

All service drop locations shall be approved by NVE prior to construction of the service entrance. The location of the point of the attachment of the service drop at the building shall be such that it can be reached with a single span, 100 feet maximum from NVE's pole with no overhang of adjacent property and with proper clearances maintained. This point of attachment will normally be on the building wall facing the nearest NVE line or on a periscope through the roof. The weather head shall not be located on any wall which is less than 24" from any common property line. When it is impractical to attach service drop below the level of the weather head, the termination shall not consist of more than 3 feet of exposed open wire and shall not extend around the corner of the building. A minimum of 18" of service entrance conductor shall be extended out of the weather head, so that an 8" drip loop can be obtained below the weather head. Meter facilities shall be located within the first ten feet of structure. The meter location must not be fenced or otherwise obscured from view of meter readers, or impair the access of operations personnel. Where NVE allows the meter facilities to be fenced, the customer shall provide a means for direct access by NVE personnel, (i.e., gate).

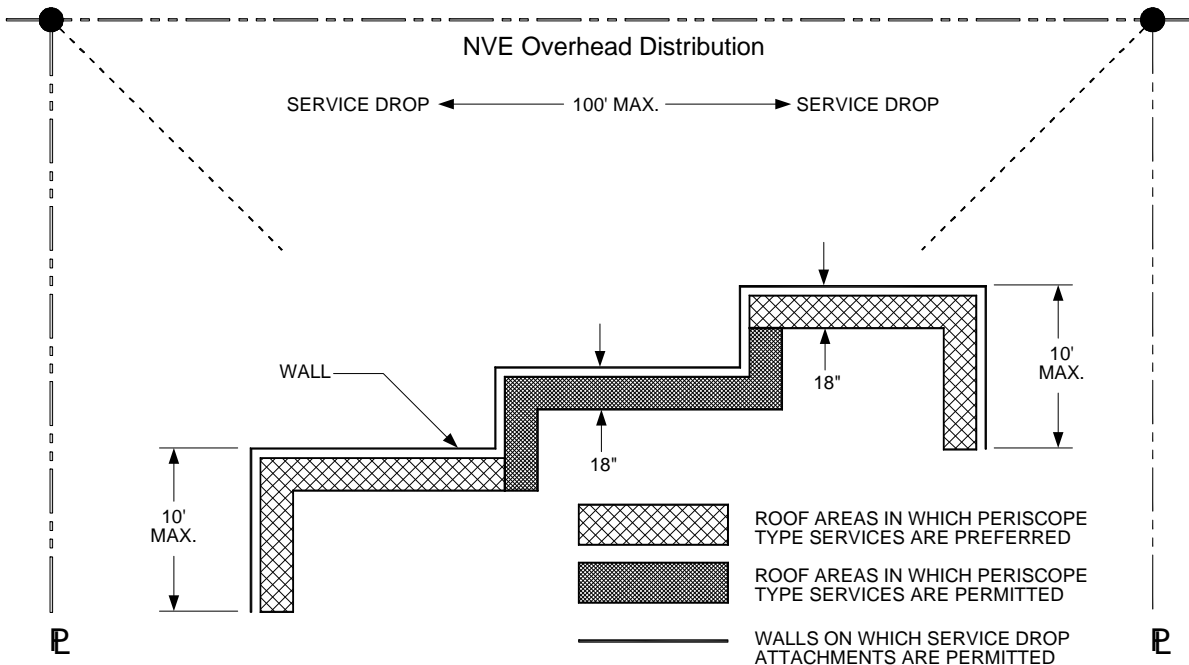

NOTES:

1. Service drop shall be attached to the wall facing the nearest NVE pole line.
2. If a preferred location is not practicable, consult NVE in regard to an alternate location.
3. All service locations are subject to NVE approval. Installation of additional facilities at the customer's expense or future relocation at his expense may be prevented by early consultation of NVE.
4. A working space (36"x36"x78") in front of all meters is required to permit installation and provide a safe working environment for NVE personnel. Any exception from this requirement must be approved by NVE.
5. The customer for architectural reasons may conceal or recess the service entrance and meter in through the outside wall where permitted by local codes.

For detailed cabinet requirements, see GM0001M, Electric Metering General, Section 5.2.

For detailed service equipment requirements, see RM0001M, Electric Metering Residential.

				Electric Service Requirements		RR-2
				Overhead Electric Service: Residential		
Drawn:	Eng:	Appr:	Date:			Revision: 1
DH	DH	MES	2/08			Page 2 of 4

Electric Service Requirements

7. Clearances

The minimum acceptable clearances for overhead service drops are outlined in National Electric Safety Code / G.O. 95. Upon request, your NVE representative will specify a point of attachment which will provide the required clearance of the service wires above thoroughfares and structures and from windows, doors, and exits of buildings.

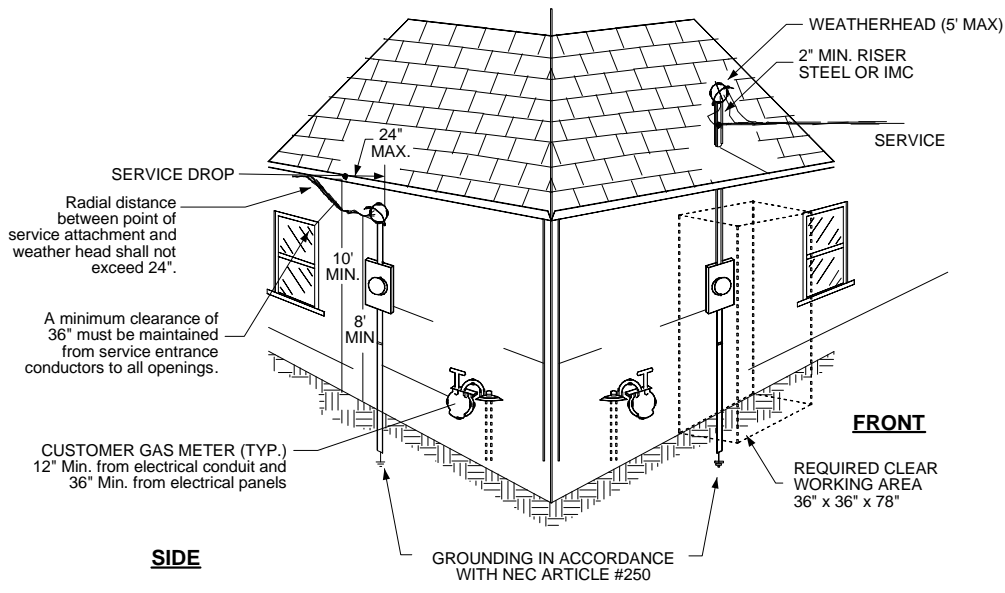
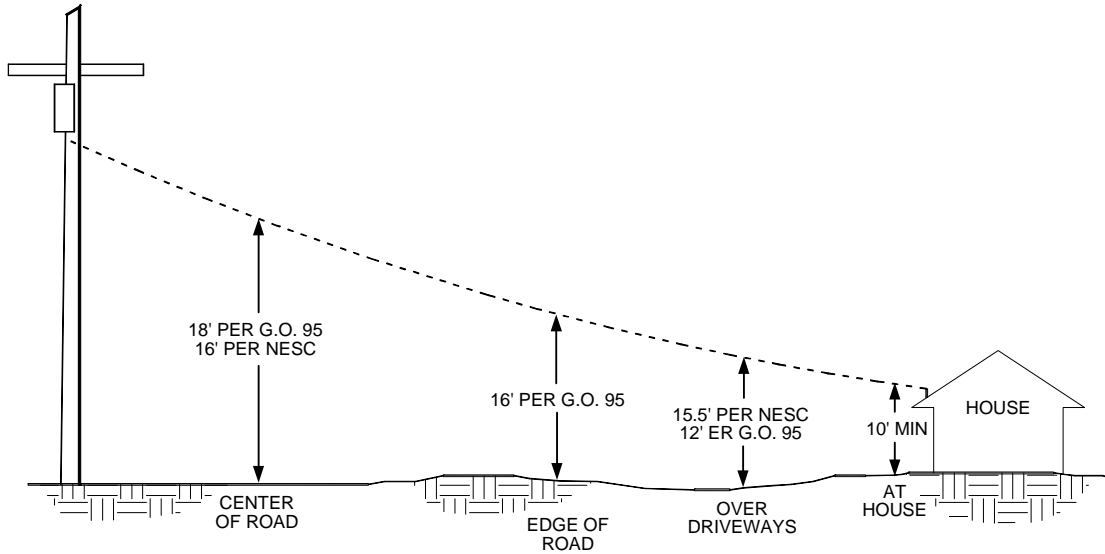

ALL SERVICE EQUIPMENT SHALL BE MADE RAIN-TIGHT BY APPROVED FITTINGS

BUILDING CLEARANCES SERVICE DETAILS

				Electric Service Requirements		RR-2
				Overhead Electric Service: Residential		
Drawn:	Eng:	Appr:	Date:	Revision: 1		Page 3 of 4
DH	DH	MES	2/08			

Electric Service Requirements

8. Service Attachments and Weather Heads

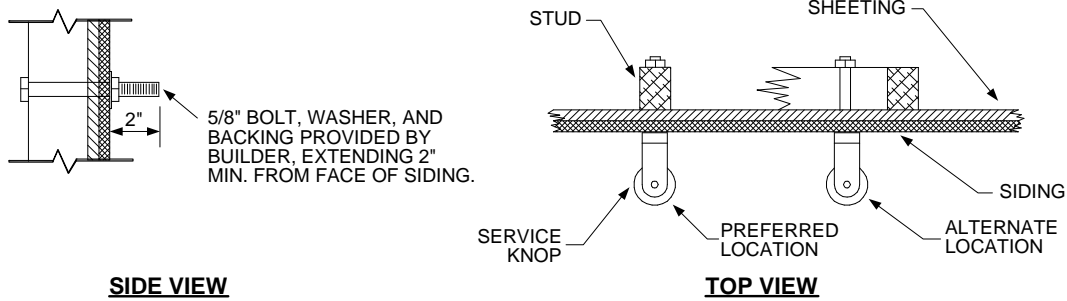

Two types of service attachments are used by NVE, service knobs which attach to the building and periscopes which extend above the roof. Typical methods of attaching residential overhead service are illustrated in this section. Where the building is high enough to permit proper clearance, the service knob can be located on roof rafters or wall studs. Customer will provide backing for service knob (min. 2"x4"), securely anchored to building frame. Service knobs will not be attached to roof fascia or wall sheathing unless proper backing is provided.

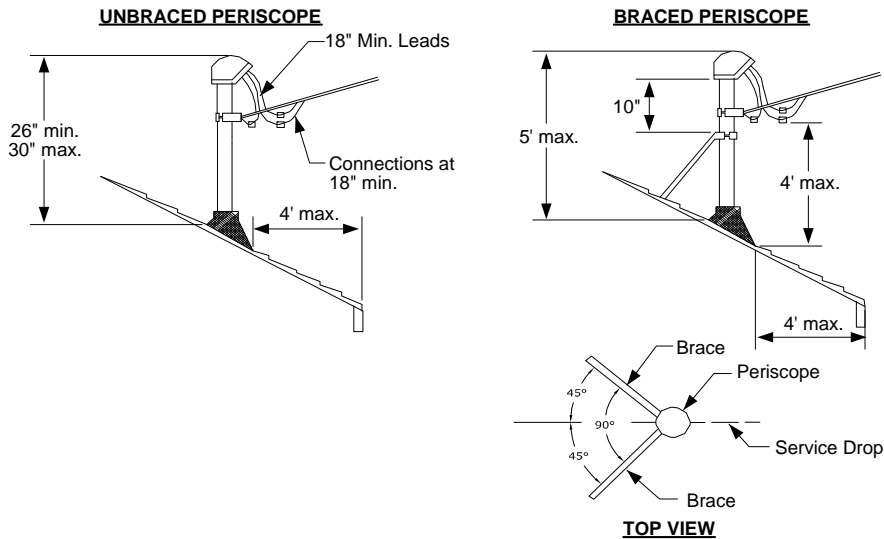

A periscope should be used when proper clearances cannot be maintained with a service knob attachment. Periscope to be minimum 2" rigid steel securely fastened to building stud. Periscope to extend minimum of 26" above roof. See NEC 230-B.

NOTES:

1. Periscope structures projecting over 30" above the roof must be braced against the pull of the service drop conductors. Bracing, when required, shall consist of two galvanized steel members installed at approximately 90° spread. Minimum size shall be 3/4" galvanized steel pipe or 1-1/4" x 1-1/4" x 1/8" galvanized steel angle. Periscope bracing shall be anchored through subroof with minimum 3/8" galvanized carriage bolts.
2. Point of attachment of service drop must be high enough to meet required clearance.
3. Alternate service attachment points must not be more than 24" from weather head.
4. Service conductor must extend minimum 18" from weather head.
5. A ladder will not be used during installation of terminations.

				Electric Service Requirements		RR-2
				Overhead Electric Service: Residential		
Drawn:	Eng:	Appr:	Date:			Revision: 1
DH	DH	MES	2/08			Page 4 of 4