

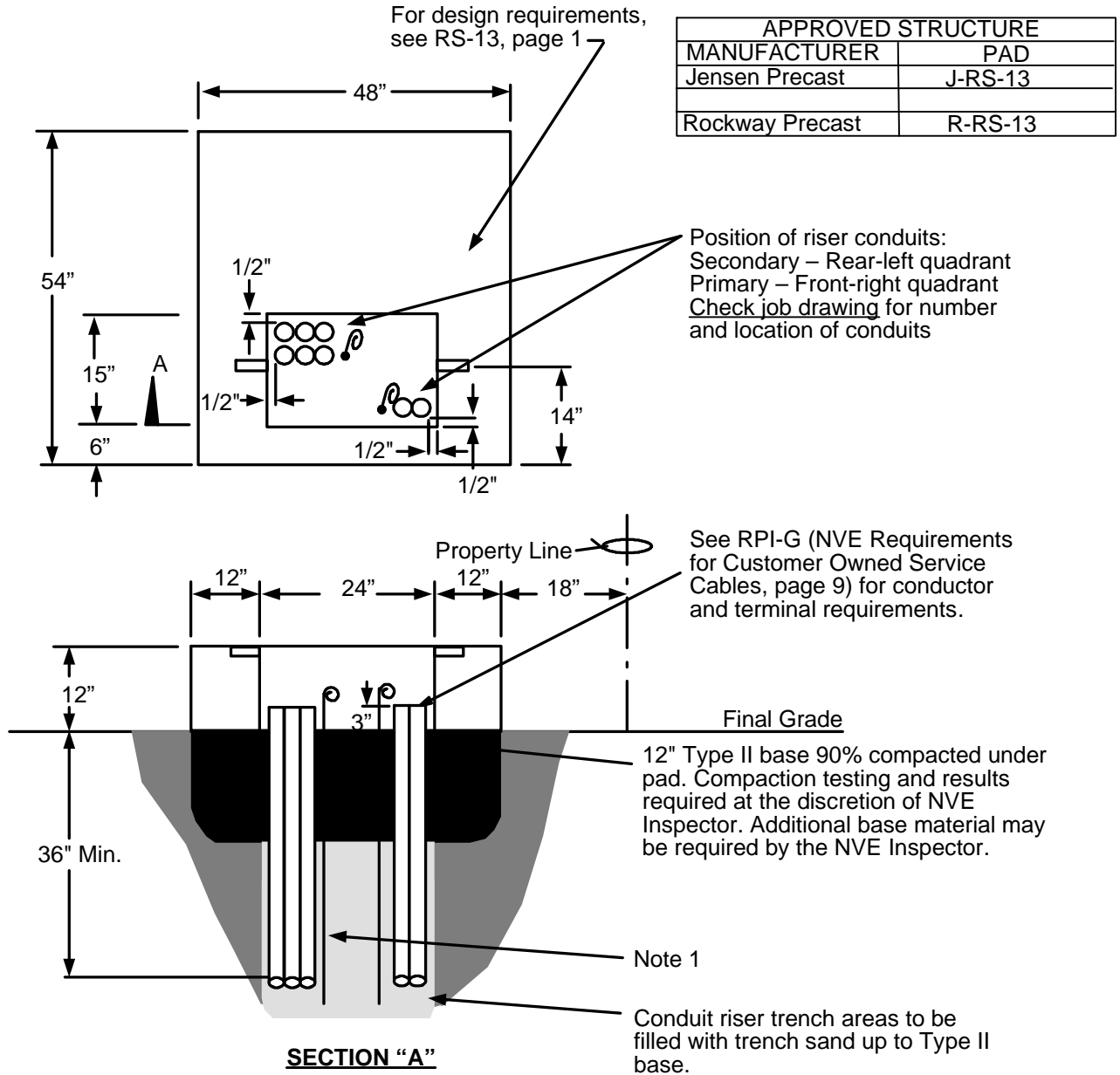

Equipment Pads

INSTALLATION REQUIREMENTS



NOTES:

1. Grounding by customer shall be 2-50' #2 stranded bare copper ground wires laid in the bottom of the conduit trench in opposite directions with 2-5' tails in the pad opening.
2. Note: Only at the discretion of NVE's inspectors, a 1/2" x 8' copper ground rod can be installed.
3. For location and clearances to other structures, see: RS-5.
4. Retaining wall required when grade from bottom of pad rises or lowers more than 1' in 5' horizontally

				Electric Service Requirements		RS-19
				Commercial Transformer Pad: One 1Ph, 12 or 25kV		
Drawn:	Eng:	Appr:	Date:			Revision: 1
DH	DH	DA	11/06			Page 1 of 2

THIS PAGE INTENTIONALLY LEFT BLANK

				Electric Service Requirements		RS-19
				Commercial Transformer Pad: One 1Ph, 12 or 25kV		
Drawn:	Eng:	Appr:	Date:	Revision: 1		
DH	DH	DA	11/06	Page 2 of 2		