

Equipment Pads

DESIGN REQUIREMENTS

TOLERANCES:

a = +0", -1 1/2"
 b = +1/4", -0"
 c = +1/2", -1/2"
 d = +1/2", -0"

REBAR SCHEDULE:

(a) = 12 ea. 27"
 (b) = 4 ea. 48"
 (c) = 5 ea. 150"

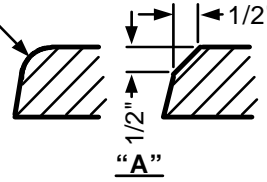

APPROVED PRECAST PAD	
MANUFACTURER	PAD
Jensen Precast	J-RS-21
Rockway Precast	R-RS-21

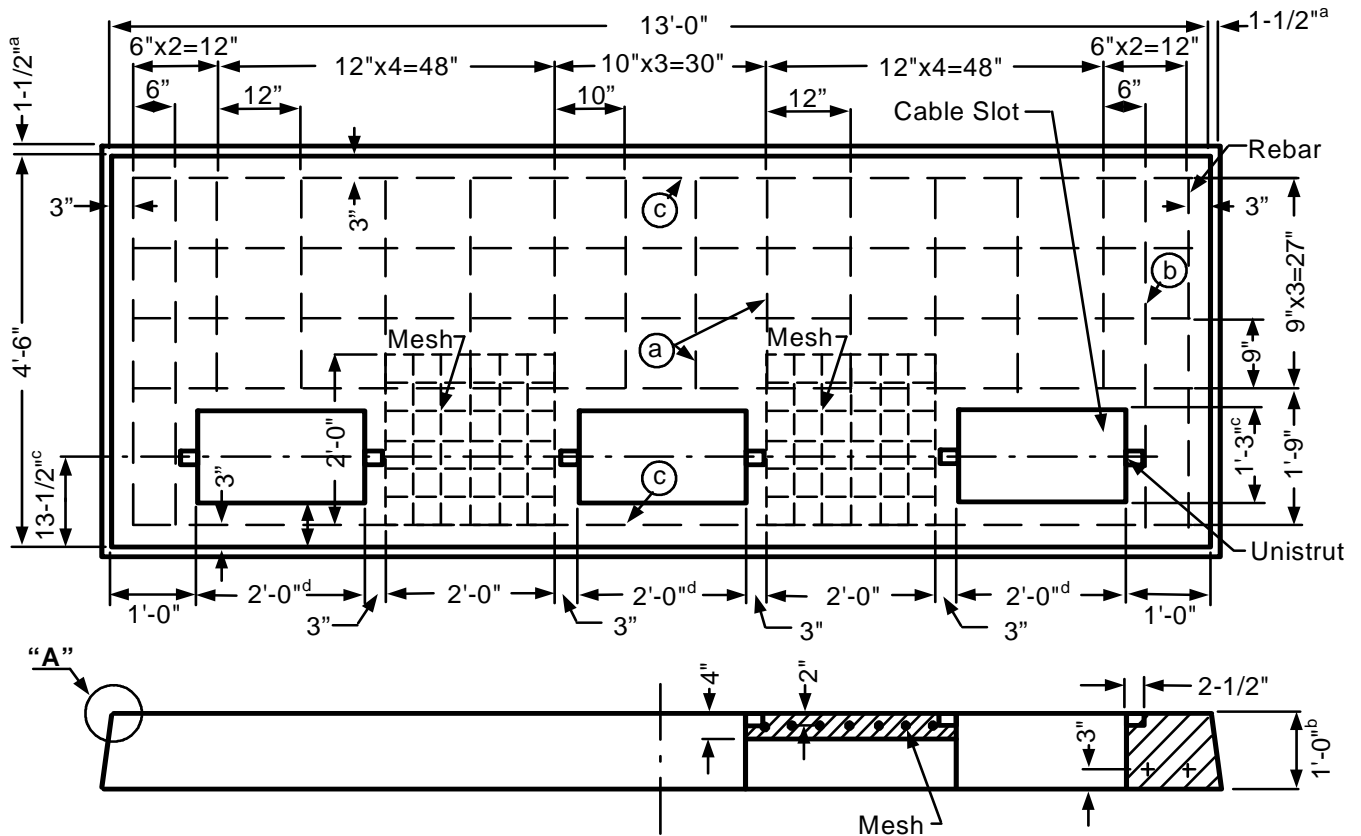

RS-21 TRANSFORMER PAD

- Rebar
 - Minimum #4
 - Placed into the above drawing according to the rebar schedule.
- Mesh
 - Welded wire fabric 4x4-W4.0xW4.0, and 2'-0"x2'-0" square.
 - Placed between the two cable slots.
- Pad
 - Two Unistruts hot dip galvanized steel type P2000HGx2-1/2".
 - Three 15"x24" cable slots.
 - Shall meet RS-G2 and RS-G3.

	Electric Service Requirements			RS-21
	Commercial Transformer Pad: Three 1Ph, 12 or 25kV			
Drawn: DH Eng: DH Appr: DA Date: 12/06				Revision: 1 Page 1 of 2

Equipment Pads

INSTALLATION REQUIREMENTS

APPROVED PRECAST PAD	
MANUFACTURER	PAD
Jensen Precast	J-RS-21
Rockway Precast	R-RS-21

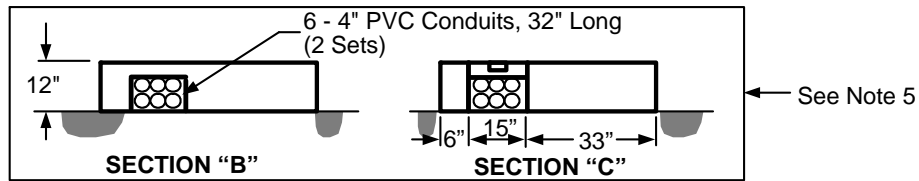
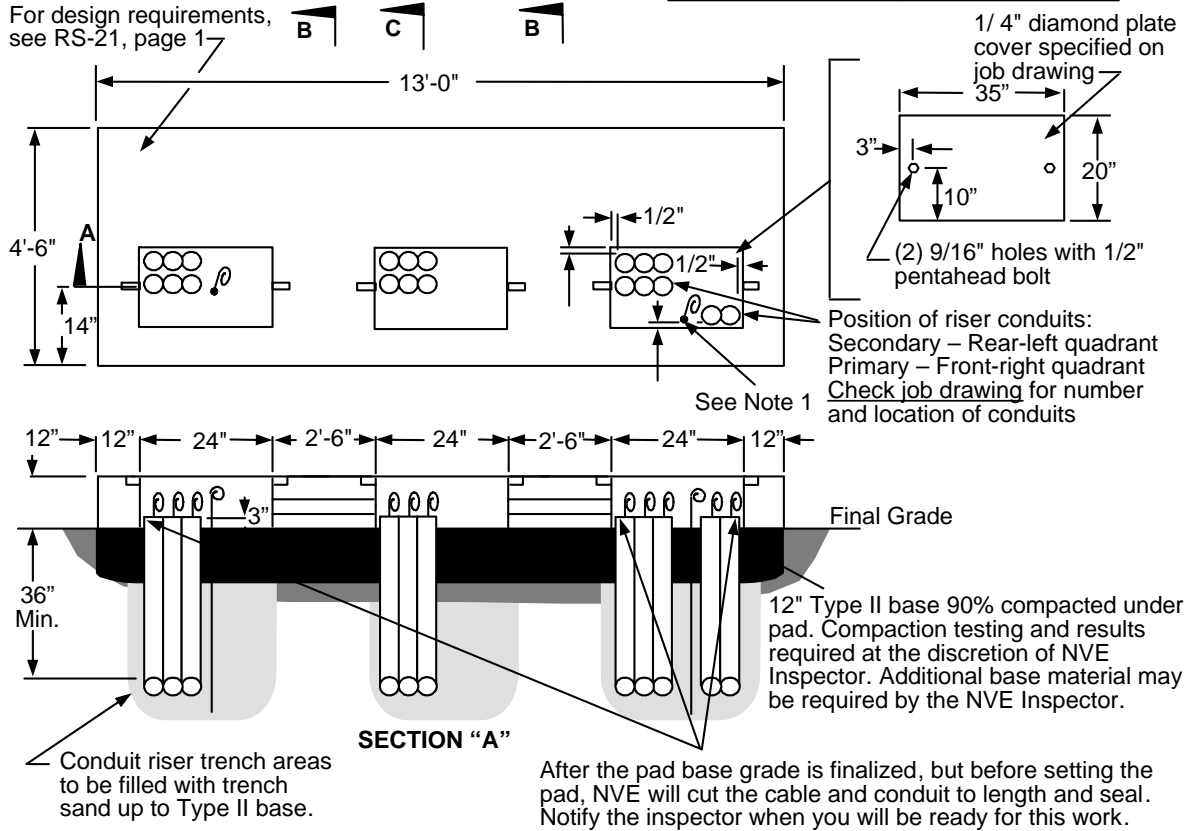

NOTES:

- Grounding by customer shall be 2-50' #2 stranded bare copper ground wires laid in the bottom of the conduit trench in opposite directions with 2-5' tails in the pad opening.
Note: Only at the discretion of NVE's inspectors, a 1/2"x8' copper ground rod can be installed.
- For location and clearances to other structures, see RS-5.
- Retaining wall required when grade from bottom of pad rises or lowers more than 1' in 5' horizontally.
- Telephone and cable TV ground wires and clamps installed by them.
- Sections "B" and "C" are for pour-in-place pads only.
- The top of the pad shall be leveled and must clear the final grade by 12".

				Electric Service Requirements		RS-21
				Commercial Transformer Pad: Three 1Ph, 12 or 25kV		
Drawn:	Eng:	Appr:	Date:			Revision: 1
DH	DH	DA	12/06			Page 2 of 2