

# Vaults and Boxes

## DESIGN REQUIREMENTS

**TOLERANCES:**  
 a = +1/2", -1/2"  
 b = +0", -1"  
 c = +0", -1/16"

APPROVED STRUCTURE	
MANUFACTURER	
Jensen Precast	J-RS-85
Rockway Precast	R-RS-85

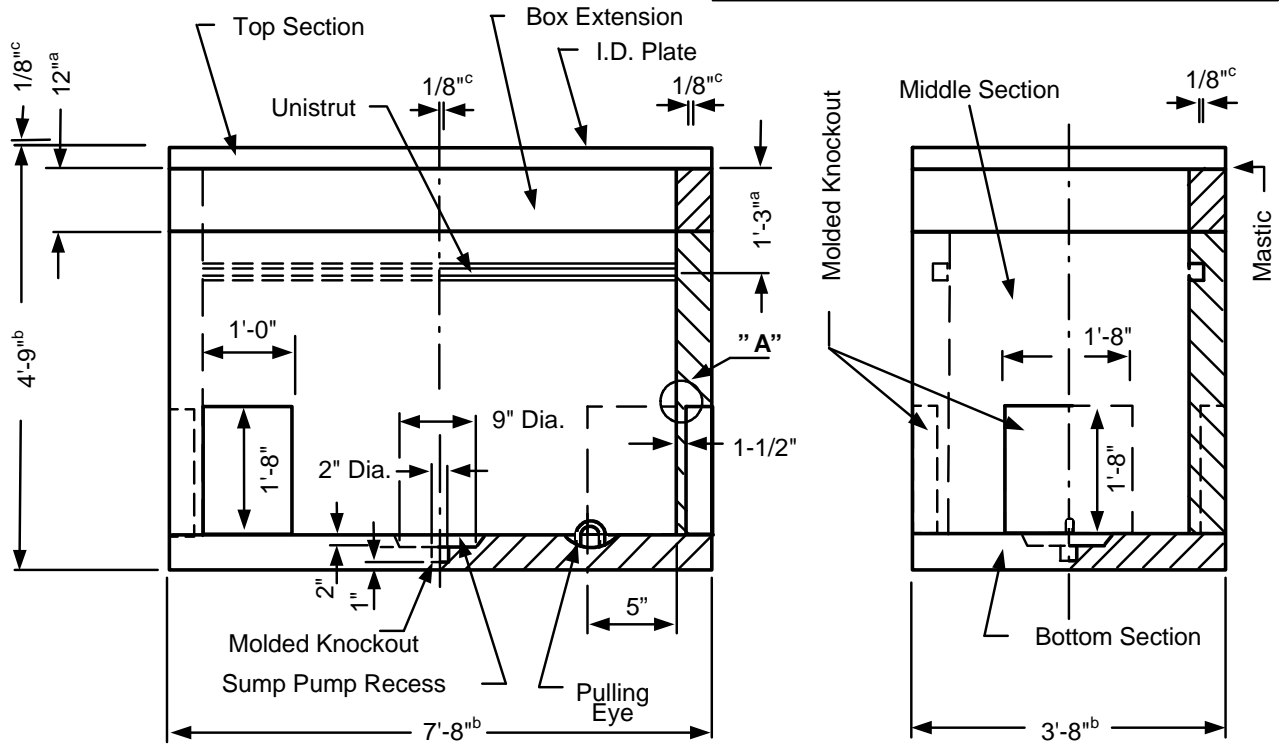

**RS-85 INTERCEPT PULL BOX**

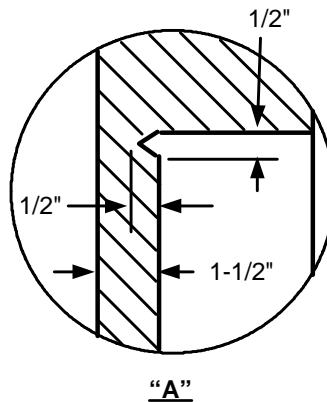

				Electric Service Requirements		<b>RS-85</b>
				<b>Intercept Box:                  36" x 84" x 48"</b>		
Drawn:	Eng:	Appr:	Date:	Revision: 2		Page 1 of 4
DB	KL	KL	11/07			

# Vaults and Boxes

## 1. Top Section (With Torsion – Assisted Lids)

1. "ELE" in 1" letters, centered, bead welded or impressed into the top of one lid section.
2. Two 5/8" slotted holes with two captive 1/2" – 13UNC stainless steel penta head bolts, and two 1/2" UNC stainless steel spring nuts placed into two covered channels (struts), which shall be welded continuously to the bottom and side of the frame under the slotted holes.
3. Both lid sections level to the top of the frame.
4. A 1" diameter hole (for a typical lifting hook), in covering lid section, with a permanent internal safety cover.
5. Two stainless steel (filled with grease) or brass bearing hinges for each lid section.
6. Provision(s) to lock each lid in the 90° open position.
7. A maximum 1/8" horizontal and vertical gap around lids, with a debris shield welded on the back side of the lids (see Figure 2).

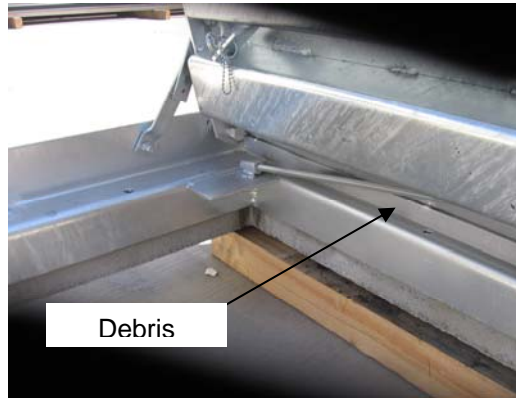



Figure 2.

8. Anchoring provision(s)
9. The frame bolted to the precast extension, and the gap sealed with mastic or similar material approved by NVE.
10. Minimum of two (0.191 sq. in. cross section) cold galvanized torsion bars (for each lid), held by provision(s) that allow easy bar replacement. Bar material – spring steel (5160H ASQ); heat treated to 42±2 R/C and straightened).
11. Maximum 35lb. pulling force required to open each lid section.
12. The open angle (by torsion bars) not to exceed 15 degrees between the lid and the frame.
13. A brass I.D. plate with dimensions of 2.5" diameter x .25" thick, which shall be installed into the top of one diamond plate in a specially built concave area.
14. Every twentieth top section assembled, tested by opening and closing the lid 25 times.

## 2. Box Section

1. 36" (W) x 84" (L) inside dimensions with tolerances of ±1".

				<b>Electric Service Requirements</b>		<b>RS-85</b>
				<b>Intercept Box: 36" x 84" x 48"</b>		
Drawn:	Eng:	Appr:	Date:			Revision: 2
DB	KL	KL	11/07			Page 2 of 4

## Vaults and Boxes

---

### 3. Middle Section

1. Two 12" (W) x 20" (H) molded knockouts in each side wall.
2. Two 20" (W) x 20" (H) molded knockouts in each end wall.
3. All knockouts with ½" notch around each knockout in middle section per detail "A" on page 1.
4. Two Unistruts, hot dip galvanized steel type P3200HG x 84" in opposite walls (stainless steel spring nuts shall be installed by NVE).
5. 36" (W) x 84" (L) inside dimensions with tolerances of ±1".

### 4. Bottom Section

1. Two steel pulling eyes in the floor.
2. A 9" diameter x 2" deep sump pump recess with 2" diameter knockout in the middle of the floor.

### 5. Entire Structure

1. All exposed steel (except torsion bars) shall be hot dip galvanized after fabrication.
2. Shall meet RS-G2 and RS-G4.

**NOTE:** For heavy frequency traffic areas, (e.g. streets, roads, etc.) use the RS-83 box.

				Electric Service Requirements		RS-85
				Intercept Box: 36" x 84" x 48"		
Drawn:	Eng:	Appr:	Date:	Revision: 2		Page 3 of 4
DB	KL	KL	11/07			

# Vaults and Boxes

## INSTALLATION REQUIREMENTS

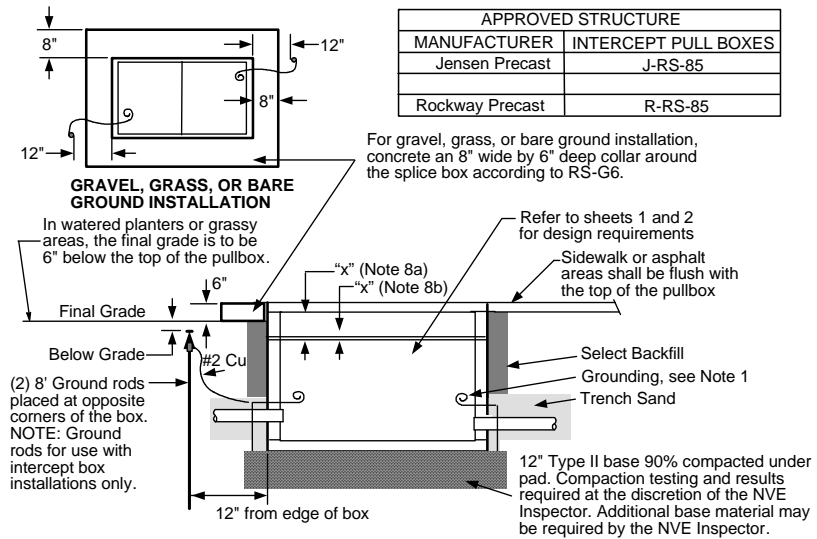

### NOTES:

1. Grounding by customer, shall be one of the following:
  - A. 2-50' lengths of #2 stranded bare copper wire laid in trench with 5' tails in the box.
  - B. Only at the discretion of the NVE Inspector, two ½" x 8' copper clad ground rods placed at opposite corners of the box may be installed.
2. The bottom surface of the manhole shall be level
3. If the ground water level is at least 3' below the bottom of the pull box, the 2" diameter knockout in the sump pump recess shall be removed.
4. To protect the cable, a 4" split conduit shall be placed over the direct buried 1/0 cable before grouting the box.
5. NVE Lineman shall stamp (impress) the UGM Identification Number into the brass I.D. plate.
6. Knockouts shall be removed from the inside of the structure.
7. Two ½" – 13 UNC pentahead stainless steel bolts and spring nuts shall be installed by NVE for each module.
8. If any final grade adjustment "x" is needed, take the following action:
  - A. -6" to 5": The NVE contractor shall exchange existing 12" extension with 6" to 17" high extension ordered from the original manufacturer.
  - B. +3" to +12": The NVE contractor may order an additional 6" to 12" height extension from the original manufacturer.
  - C. Below -6" and above +12": Any extension shorter than 6" or exceeding 12" in height shall be subject to Regional Standards approval.
9. The box may be installed in sidewalks and non traffic areas; for installations in delivery alleys behind commercial developments specify an RS-82B three piece lid.
10. There shall be a minimum 6' clearance from the RS-85 box to the centerline of a fire hydrant.
11. Retaining wall required when grade from bottom of pad rises or lowers more than 1' in 5' horizontally or when required by developer as perimeter wall.
12. For heavy frequency traffic areas (e.g. streets, roads, etc.), use the RS-83 box.

				<b>Electric Service Requirements</b>		<b>RS-85</b>
				<b>Intercept Box: 36" x 84" x 48"</b>		
Drawn:	Eng:	Appr:	Date:			Revision: 2
DB	KL	KL	11/07			Page 4 of 4