

Residential Solar Heating Collectors

Solar collectors are the heart of most solar energy systems. The collector absorbs the sun's light energy and changes it into heat energy. This publication describes the different types of solar collectors used for residences. It also briefly covers the solar heating systems for which they are best suited. For more detailed information on these different solar heating systems, contact The Energy Efficiency and Renewable Energy Clearinghouse (EREC—see the *Source List* at the end of this publication).

Solar collectors heat a fluid, either air or liquid. This fluid then is used to heat—directly or indirectly—the following.

- Water for household use
- Indoor spaces
- Water for swimming pools
- Water or air for commercial use
- Air to regenerate desiccant (drying) material in a desiccant cooling system.

There are several types of solar collectors used for residences. These are flat-plate, evacuated-tube, and concentrating collectors.

Flat-Plate Collectors

Flat-plate collectors are the most common collector for residential water-heating and space-heating installations. A typical flat-plate collector is an insulated metal box with a glass or plastic cover—called the glazing—and a dark-colored absorber plate. The glazing can be transparent or translucent. Translucent (transmitting light only), low-iron glass is a common glazing material for flat-plate collectors because low-iron glass transmits a high percentage of the total available solar energy. The glazing allows the light to strike the absorber plate but reduces the amount of heat that can escape. The sides and bottom of the collector are usually insulated, further minimizing heat loss.

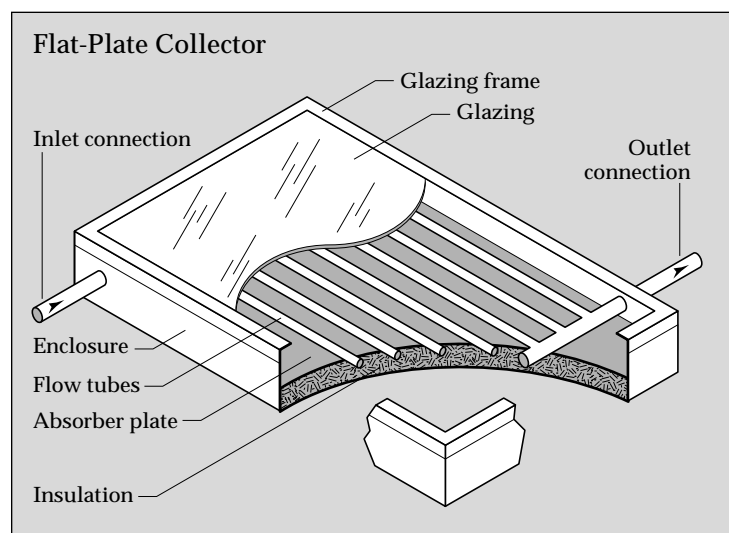

A typical flat-plate collector is an insulated metal box with a glass or plastic cover and a dark-colored absorber plate. The flow tubes can be routed in parallel, as shown here, or in a serpentine pattern.

The absorber plate is usually black because dark colors absorb more solar energy than light colors. Sunlight passes through the glazing and strikes the absorber plate, which heats up, changing solar radiation into heat energy. The heat is transferred to the air or liquid passing through the collector. Absorber plates are commonly covered with “selective coatings,” which retain the absorbed sunlight better and are more durable than ordinary black paint.



This document was produced for the U.S. Department of Energy (DOE) by the National Renewable Energy Laboratory (NREL), a DOE national laboratory. The document was produced by the Information Services Program, under the DOE Office of Energy Efficiency and Renewable Energy. The Energy Efficiency and Renewable Energy Clearinghouse (EREC) is operated by NCI Information Systems, Inc., for NREL / DOE. The statements contained herein are based on information known to EREC and NREL at the time of printing. No recommendation or endorsement of any product or service is implied if mentioned by EREC.



The heart of a solar energy system is the solar collector—a device that absorbs the sun’s light energy and changes it into heat energy.

Absorber plates are often made of metal—usually copper or aluminum—because they are both good heat conductors. Copper is more expensive, but is a better conductor and is less prone to corrosion than aluminum.

Flat-plate collectors fall into two basic categories: liquid and air. And both types can be either glazed or unglazed.

Liquid Collectors

In a liquid collector, solar energy heats a liquid as it flows through tubes in or adjacent to the absorber plate. For this type of collector, the flow tubes are attached to the absorber plate so the heat absorbed by the absorber plate is readily conducted to the liquid.

The flow tubes can be routed in parallel, using inlet and outlet headers, or in a serpentine pattern. A serpentine pattern eliminates the possibility of header leaks and ensures uniform flow. A serpentine pattern is not appropriate, however, for systems that must drain for freeze protection because the curved flow passages will not drain completely.

The simplest liquid systems use potable household water, which is heated as it passes directly through the collector and then flows to the house to be used for bathing, laundry, etc. This design is known as an “open-loop” (or “direct”) system. In areas where freezing temperatures are common, however, liquid collectors must either drain the water when the temperature drops or use an antifreeze type of heat-transfer fluid.

In systems with heat-transfer fluids, the transfer fluid absorbs heat from the collector and then passes through a heat exchanger. The heat exchanger, which generally is in the water storage tank inside the house, transfers heat to the water. Such designs are called “closed-loop” (or “indirect”) systems. For information on solar water-heating systems, contact EREC.

Glazed liquid collectors are used for heating household water and sometimes for space heating. Unglazed liquid collectors are commonly used to heat water for swimming pools. Because these collectors need not withstand high temperatures, they can use less expensive materials such as plastic or rubber. They also do not require freeze-proofing because swimming pools are generally used only in warm weather.

Air Collectors

Air collectors are simple, flat-plate collectors used primarily for space heating. The absorber plates in air collectors can be metal sheets, layers of screen, or non-metallic materials. The air flows past the absorber by natural convection or when forced by a fan. Because air conducts heat much less readily than liquid does, less heat is transferred between the air and the absorber than in a liquid collector.

In some solar air-heating systems, fins or corrugations on the absorber are used to increase air turbulence and improve heat transfer. The disadvantage of this strategy is that it can also increase the amount of power needed for fans and, thus, increase the costs of operating the system. In colder climates, the air is routed between the absorber plate and the back insulation to reduce heat loss through the glazing. However, if the air will not be heated more than 30°F (17°C) above the outdoor temperature, the air can flow on both sides of the absorber

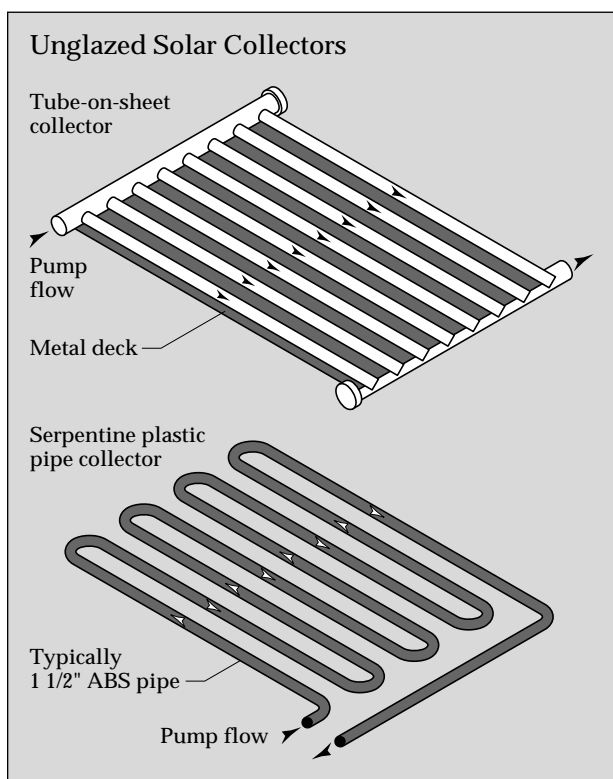

Unglazed collectors are commonly used to heat swimming pool water. No glazing is needed because the system is used when both outdoor temperatures and solar radiation levels are high.

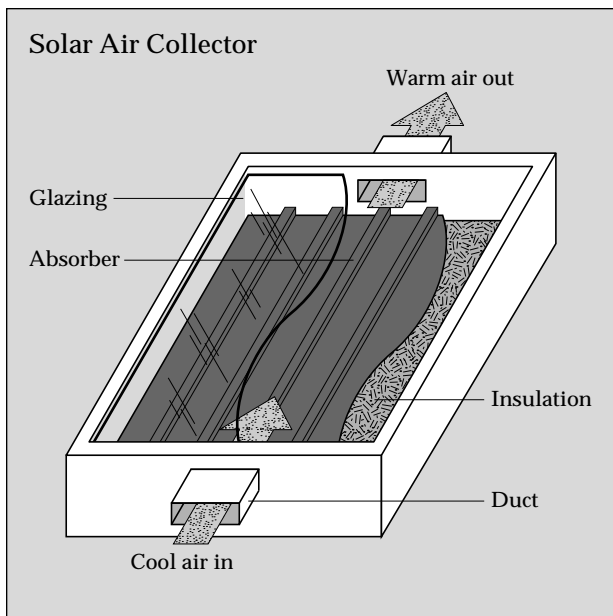

An air collector is a simple flat-plate collector used mainly for space heating. Air flows through the collector by natural convection or when forced by a fan.

plate without sacrificing efficiency.

Air systems have the advantage of eliminating the freezing and boiling problems associated with liquid systems. Although leaks are harder to detect and plug in an air system, they are also less troublesome than leaks in a liquid system. Air systems can often use less-expensive materials, such as plastic glazing, because their operating temperatures are usually lower than those of liquid collectors.

collector consists of rows of parallel transparent glass tubes, each of which contains an absorber tube (in place of the absorber plate in a flat-plate collector) covered with a selective coating. Evacuated-tube collectors are modular—tubes can be added or removed as hot-water needs change.

When evacuated tubes are manufactured, air is evacuated from the space between the two tubes, forming a vacuum. Conductive and convective heat losses are eliminated because there is no air to conduct heat or to circulate and cause convective losses. There can still be some radiant heat loss (heat energy will move through space from a warmer to a cooler surface, even across a vacuum). However, this loss is small and of little consequence compared with the amount of heat transferred to the liquid in the absorber tube.

Evacuated-tube collectors are available in a number of designs. Some use a third glass tube inside the absorber tube or other configurations of heat-transfer fins and fluid tubes. One commercially available evacuated-tube collector stores 5 gallons (19 liters) of water in each tube, eliminating the need for a separate solar storage tank. Reflectors placed behind the evacuated tubes can help to focus additional sunlight on the collector.

Evacuated-Tube Collectors

Evacuated-tube collectors heat water in residential applications that require higher temperatures. In an evacuated-tube collector, sunlight enters through the outer glass tube, strikes the absorber tube, and changes to heat. The heat is transferred to the liquid flowing through the absorber tube. The

Because unglazed transpired air collectors require no glazing or insulation, they are inexpensive to manufacture, resulting in a very cost-effective source of solar heat.

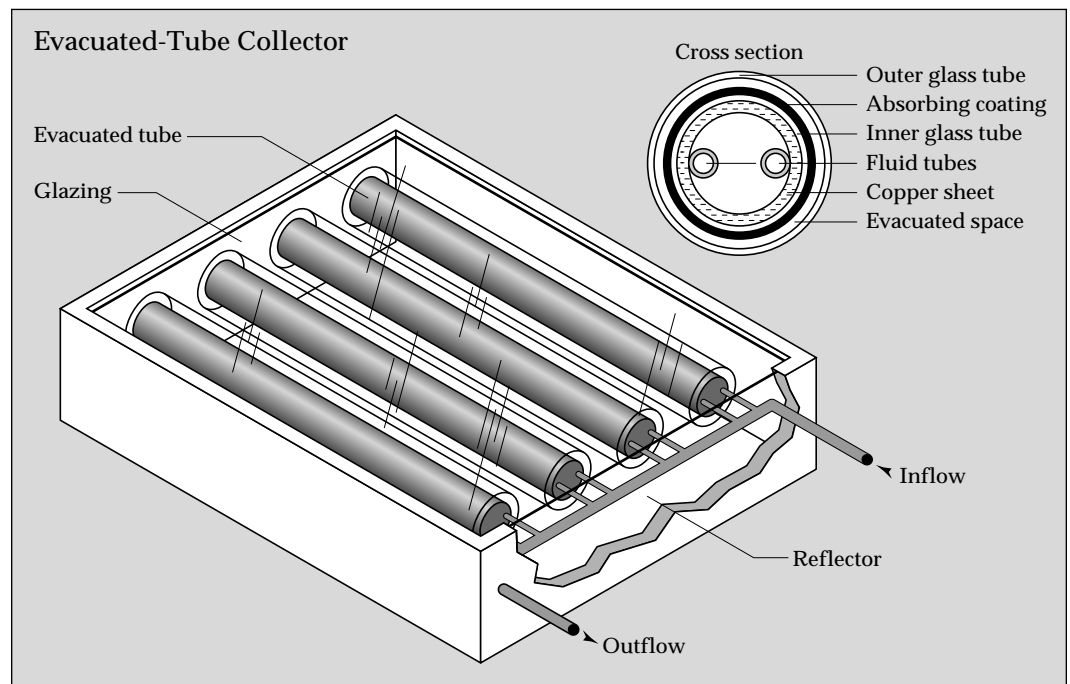

An evacuated-tube collector generally consists of a fluid-filled absorber tube surrounded by a vacuum.

Solar collectors can heat air and water cost effectively for residential applications.

These collectors are more efficient than flat-plate collectors for a couple of reasons. First, they perform well in both direct and diffuse solar radiation. This characteristic, combined with the fact that the vacuum minimizes heat losses to the outdoors, makes these collectors particularly useful in areas with cold, cloudy winters. Second, because of the circular shape of the evacuated tube, sunlight is perpendicular to the absorber for most of the day. For comparison, in a flat-plate collector that is in a fixed position, the sun is only perpendicular to the collector at noon. While evacuated-tube collectors achieve both higher temperatures and higher efficiencies than flat-plate collectors, they are also more expensive.

called the focal line. The receiver is located at the focal point or along the focal line. A heat-transfer fluid flows through the receiver and absorbs heat.

These collectors reach much higher temperatures than flat-plate collectors. However, concentrators can only focus direct solar radiation, with the result being that their performance is poor on hazy or cloudy days. Concentrators are most practical in areas of high insolation (exposure to the sun's rays), such as those close to the equator and in the desert southwest United States.

Concentrators perform best when pointed directly at the sun. To do this, these systems use tracking mechanisms to move the collectors during the day to keep them focused on the sun. Single-axis trackers move east to west; dual-axis trackers move east and west and north and south (to follow the sun throughout the year). In addition to these mechanical trackers, there are passive trackers that use freon to supply the movement. While not widely used, they do provide a low-maintenance alternative to mechanical systems.

Concentrators are used mostly in commercial applications because they are expensive and because the trackers need frequent maintenance. Some residential solar energy systems use parabolic-trough concentrating systems. These installations can provide hot water, space heating, and water purification. Most residential systems use single-axis trackers, which are less expensive and simpler than dual-axis trackers.

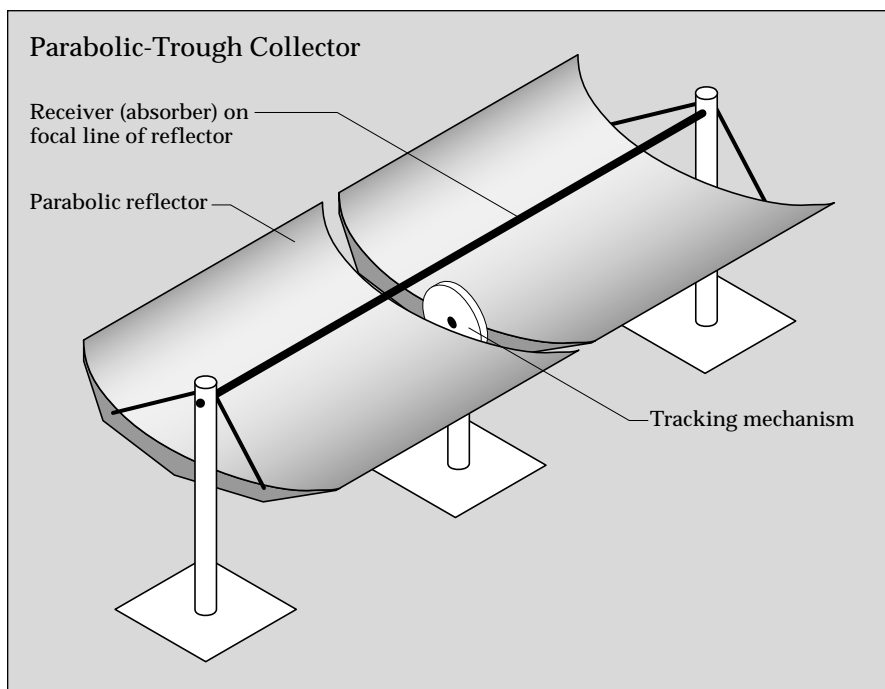

A parabolic-trough collector can achieve higher temperatures than flat-plate or evacuated-tube collectors because it focuses sunlight collected over a large area onto a receiver located along a narrow focal line.

Concentrating Collectors

Concentrating collectors use mirrored surfaces to concentrate the sun's energy on an absorber called a receiver. Concentrating collectors also achieve high temperatures, but unlike evacuated-tube collectors, they can do so only when direct sunlight is available. The mirrored surface focuses sunlight collected over a large area onto a smaller absorber area to achieve high temperatures. Some designs concentrate solar energy onto a focal point, while others concentrate the sun's rays along a thin line

Technological Improvements

The efficiency of solar heating systems and collectors has improved from the early 1970s and costs have dropped somewhat. The efficiencies can be attributed to the use of low-iron, tempered glass for glazing (low-iron glass allows the transmission of more solar energy than conventional glass), improved insulation, and the development of durable selective coatings.

Low-Tech Solar Collectors

Several inexpensive, “low-tech” solar collectors with specific functions are also available commercially. Batch heaters are simple, effective solar water heaters; solar box cookers are used for cooking and for purifying water; and solar stills produce inexpensive distilled water from virtually any water source.

Batch heaters, also known as “breadbox” or integrated collector systems, use one or more black tanks filled with water and placed in an insulated, glazed box. Some boxes include reflectors to increase the solar radiation. Solar energy passes through the glazing and heats the water in the tanks. These devices are inexpensive solar water heaters but must be drained or protected from freezing when temperatures drop below freezing.

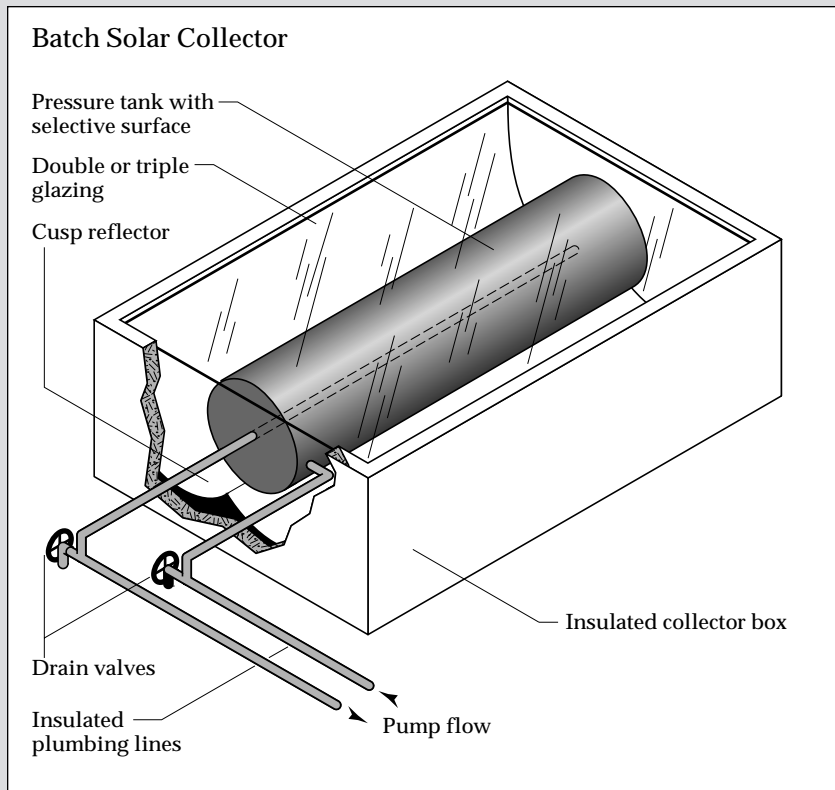

A batch heater is a simple solar water heater that uses one or more black tanks filled with water and placed in an insulated, glazed box.

Solar box cookers are inexpensive to buy and easy to build and use. They consist of a roomy, insulated box lined with reflective material, covered with glazing, and fitted with an external reflector. Black cooking pots serve as absorbers, heating up more quickly than shiny aluminum or stainless steel cookware. Box cookers can also be used to kill bacteria in water if the temperature can reach the boiling point.

Solar stills provide inexpensive distilled water from even salty or badly contaminated water. They work on the principle that water in an open container will evaporate. A solar still uses solar energy to speed up the evaporation process. The stills consist of an insulated, dark-colored container covered with glazing that is tilted so the condensing fresh water can trickle into a collection trough. A small solar still, which is about the size of your kitchen stove, can produce two gallons of distilled water on a sunny day.

Also, a new solar air collector, formerly used primarily for commercial buildings, is now available for homes. Called a transpired collector, it eliminates the cost of the glazing, the metal box, and the insulation. This collector is made of black, perforated metal. The sun heats the metal, and a fan pulls air through the holes in the metal, which heats the air. For residential installations, these collectors are available in 8-foot by 2.5-foot (2.4-meter by 0.8-meter) panels capable of heating 40 cubic feet per minute (0.002 cubic meters per second) of outside air. On a sunny winter day, the panel can produce temperatures up to 50°F (28°C) higher than the outdoor air temperature. Transpired air collectors not only heat air, but also improve indoor air quality by directly preheating fresh outdoor air.

These collectors have achieved very high efficiencies—more than 70% in some commercial applications. Plus, because the collectors require no glazing or insulation, they are inexpensive to manufacture. All these factors make transpired air collectors a very cost-effective source of solar heat.

There are other prototype cooling systems operating today. Some use heat from solar collectors for absorption cooling. Others are being used to renew the desiccant material in desiccant cooling systems. Desiccants, such as silica gel, naturally attract moisture. They are used to reduce humidity and the resulting cooling loads in hot, humid climates.

Collector Performance Ratings

When you are shopping for solar collectors, you can compare their performance. Look for a Solar Rating & Certification Corporation (SRCC) or Florida Solar Energy Center (FSEC) sticker on the equipment you are considering to check their comparative performance ratings. For more information on SRCC's or FSEC's performance standards, contact EREC.

A Bright Future

Solar collectors can be used for nearly any process that requires heat. As environmental laws become stricter and the price of conventional power increases, it is likely that solar collectors will be integrated into many applications.

Source List

The following organizations can provide you with more information about different types of solar collectors.

American Solar Energy Society (ASES)
2400 Central Avenue, Unit G-1
Boulder, CO 80301
(303) 443-3130
Fax: (303) 443-3212

ASES is a nonprofit educational organization founded in 1954 to encourage the use of solar energy technologies. ASES publishes a bimonthly magazine, *Solar Today*, and offers a variety of solar publications through its catalogue.

Florida Solar Energy Center (FSEC)
1679 Clearlake Road
Cocoa, FL 32922-5703
(407) 638-1000
Fax: (407) 638-1010

FSEC is one of the largest and most active alternative energy centers in the country. The FSEC staff conducts research on a range of solar technologies, offers solar energy workshops, and distributes many free publications to the public.

Solar Energy Industries Association (SEIA)
122 C Street, NW, 4th Floor
Washington, DC 20001
(202) 383-2600
Fax: (202) 383-2670

SEIA provides lists of solar-equipment manufacturers and dealers and publishes a magazine called the *Solar Industry Journal*.

Solar Rating & Certification Corporation (SRCC)
122 C Street, NW, 4th Floor
Washington, DC 20001
(202) 383-2570

SRCC rates and certifies the performance of solar equipment. The SRCC offers a directory of certified solar energy systems and collectors, as well as a document (OG-300-91) that details the operating guidelines and minimum standards for certifying solar hot-water systems.

For information about many kinds of energy efficiency and renewable energy topics, contact:

The Energy Efficiency and Renewable Energy
Clearinghouse (EREC)
P.O. Box 3048
Merrifield, VA 22116
(800) DOE-EREC (363-3732)
Fax: (703) 893-0400
Email: doe.erec@nciinc.com

EREC provides free general and technical information to the public on the many topics and technologies pertaining to energy efficiency and renewable energy.

You may also contact your state and local energy offices as well as your local solar energy association for region-specific information on solar collectors.

Reading List

The following publications provide further information about solar collectors. The list is not exhaustive, nor does the mention of any publication constitute a recommendation or endorsement.

Books, Pamphlets, and Reports

Consumer Guide to Solar Energy, S. Sklar and K. Sheinkopf, Bonus Books, Inc., 160 East Illinois Street, Chicago, IL 60611, 1991.

The Fuel Savers, B. Anderson, Morning Sun Press, Lafayette, CA, 1991.

The New Solar Home Book, B. Anderson and M. Riorden, Brick House, Amherst, NH, 1987.

Periodicals

Home Energy Magazine, 2124 Kittredge Street, No. 95, Berkeley, CA 94704-9942, (510) 524-5405. *Home Energy Magazine* is a source of information on reducing energy consumption.

Solar Industry Journal, Solar Energy Industries Association, 122 C Street, NW, 4th Floor, Washington, DC 20001. *Solar Industry Journal* has information on commercializing new technologies, case studies of commercially available technologies, and articles on government policies and regulations that affect businesses in the renewable-energy industry.

Solar Today, 2400 Central Avenue, Unit G-1, Boulder, CO 80301. *Solar Today* covers all the solar technologies, both mature and emerging, in a general-interest format. Each issue includes a solar building case study.