

PADMOUNT EQUIPMENT LOCATIONS / CLEARANCES

Where NVE desires to install transformers and padmount equipment on customer's premises, the customer shall furnish a satisfactory right-of-way for such purposes, and shall provide adequate space for the installation.

Padmount equipment shall conform to the following:

- A. Padmount transformers/equipment shall **not** be located directly in front of doors, stairways, beneath windows which can be opened, or where they will obstruct the vision of vehicular traffic. The front (doors) of padmount equipment shall open away from any structure. See Figures 1 - 7.
- B. Padmount transformers/equipment shall be located at least the minimum distance away from buildings or other structures to ensure adequate space for operating, proper ventilation, to minimize vibration hums, and to meet fire safety requirements.

Feature	Clearance Distance
Noncombustible walls, (doesn't burn) provided the side of the equipment facing the wall does not have doors. A clear level 10 ft area must be provided in front of equipment doors to allow personnel access for the operation and maintenance of the equipment.	3 ft
Combustible walls (including stucco*), main doors, windows, air intakes/exhaust vents, stairs and fire escapes.	10 ft
Gas service meter relief vents.	3 ft
Fire sprinkler valves, standpipes and fire hydrants.	6 ft
The water's edge of a swimming pool or any body of water.	15 ft
Facilities used to dispense hazardous liquids or gases (service station gas pumps or propane bulk dispensing.	20 ft
Facilities used to store hazardous liquids or gases (service station fuel storage tank filler openings or emergency generator fueling points.	10 ft
* Stucco on wood framing is combustible: Stucco on metal framing is non-combustible. (1). Clearances between pad mount equipment and structures must be measured from the closest metal portion of the equipment closest to the structure (including overhangs). (2). Consult local building and fire codes for more detailed customer information.	

- C. A clear vehicle passageway of 12 feet minimum shall be available at all times, immediately adjacent (within 8') to one side of the equipment to provide an accessible roadway for equipment maintenance. This passageway shall be designed to meet H-20, (20-ton) construction.
- D. Transformer and equipment structures will normally be installed only in non-traffic areas. Transformer and equipment protection is required when NVE equipment is exposed to traffic. This protection may be in the form of barriers, barricades (See PE0009U) or curb. A curb must have a minimum height of 6" and be at least 6" thick and its front face located 54" minimum from the equipment foundation (pad).

	VOLUME 17 – ENGINEERING & CONSTRUCTION STANDARD	PE0010U Revision: 6 Page 1 of 5								
	PADMOUNTED EQUIPMENT LOCATIONS & CLEARANCES									
<table border="1" style="width: 100%; border-collapse: collapse;"> <tr> <td style="width: 25%;">Drawn:</td> <td style="width: 25%;">Eng:</td> <td style="width: 25%;">Appr:</td> <td style="width: 25%;">Date:</td> </tr> <tr> <td style="text-align: center;">JL</td> <td style="text-align: center;">MB</td> <td style="text-align: center;">DA</td> <td style="text-align: center;">11/14</td> </tr> </table>	Drawn:	Eng:	Appr:	Date:	JL	MB	DA	11/14		
Drawn:	Eng:	Appr:	Date:							
JL	MB	DA	11/14							

- E. Three phase transformers and equipment (switches) will have a 10 foot long by the pad width, flat level surface in front of the opening for operating the switch or transformer by NVE personal. Suitable materials are concrete, asphalt or paving bricks. The clear surface will be reviewed by the planner and inspector prior to energization of the equipment.
- F. Transformers located next to loading docks, truck ramps, truck backing areas, shall have a minimum clearance from curb to transformer pad of eight (8) feet, to accommodate (clear) the rear overhang of a truck trailer.

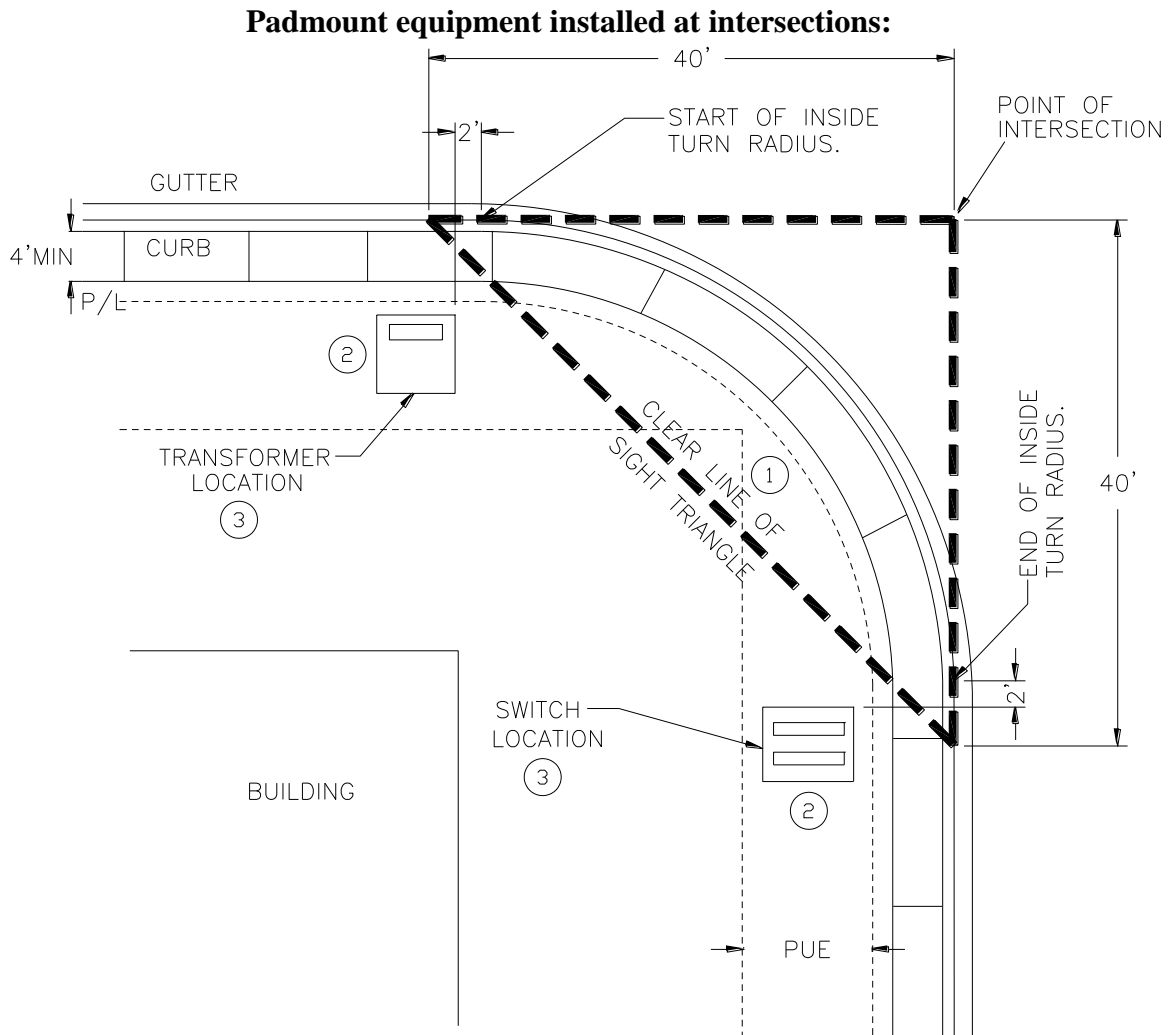

FIGURE 1

NOTES:

1. All padmount equipment shall be placed in the P.U.E. outside the "clear line of sight triangle".
2. Equipment shall be placed on level, compacted areas with a clear and level 10 ft area to be maintained in front of the equipment doors as well as a 30" (min.) space adjacent to all other sides of the equipment.
3. Refer to NVE standard TE0040U, in Section 6.0 for installations on a slope.

	VOLUME 17 – ENGINEERING & CONSTRUCTION STANDARD			PE0010U
	PADMOUNTED EQUIPMENT LOCATIONS & CLEARANCES			
Drawn:	Eng:	Appr:	Date:	Revision: 6
JL	MB	DA	11/14	Page 2 of 5

Padmount transformers installed behind decorative walls.

Adequate surrounding air space must be maintained for the required transformer "heat loss" ventilation. Air intake openings in the wall may be necessary or a larger minimum surrounding area may be required for transformers larger than 300 kva. *Transformer loading may have to be limited to its nameplate rating.* Customer service planners should make sure that the builder is made aware of this requirement.

Working space and fire safety requirements:

Padmount equipment can be a fire hazard since it contains flammable oil. *Figures 2 thru 7*, show detailed clearances to buildings required for fire safety. Fire safety clearances can be reduced by building a suitable masonry fire barrier wall 3' from the back or side of the equipment to the side of the combustible wall (see figures below). Barriers must be at least 9' wide and 15' tall. If there is a combustible overhang on the building, that overhang must be 16' or greater from the bottom of the transformer (10' radial clearance from a 6' high transformer).

All NVE equipment will be installed in accessible areas only, and have unobstructed vertical access for the installation and removal of the equipment. It will be the builders' responsibility to check that all applicable NEC, municipality and insurance regulations are met.

Pad mounted equipment locations and clearances are minimum requirements only and are intended as a design guide. They do not necessarily represent the final design criteria for any particular project. NVE reserves the right to accept, reject or to approve all applications of this particular standard before construction. Please consult the particular designer/ planner for your particular project to ensure the design is acceptable. Only NVE approved final drawings will be used for construction/ inspection purposes of NVE facilities.

Adequate storm water drainage and runoff protection must be provided to prevent flooding of the NVE electrical equipment. Any device that cannot be maintained or safely operated will not be installed.

				VOLUME 17 – ENGINEERING & CONSTRUCTION STANDARD		PE0010U
				PADMOUNTED EQUIPMENT LOCATIONS & CLEARANCES		
Drawn:	Eng:	Appr:	Date:	Revision: 6		Page 3 of 5
JL	MB	DA	11/14			

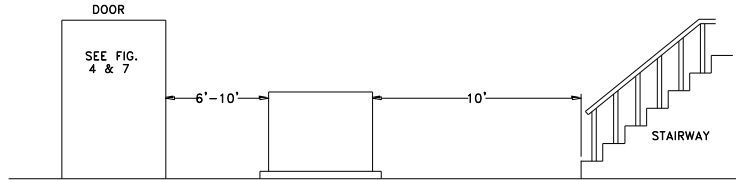

FIGURE 2

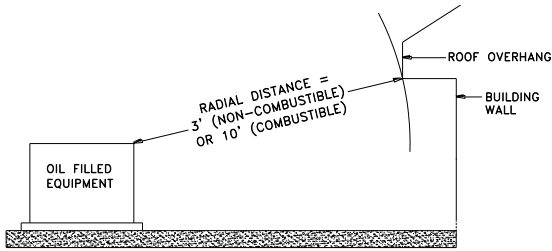

FIGURE 3

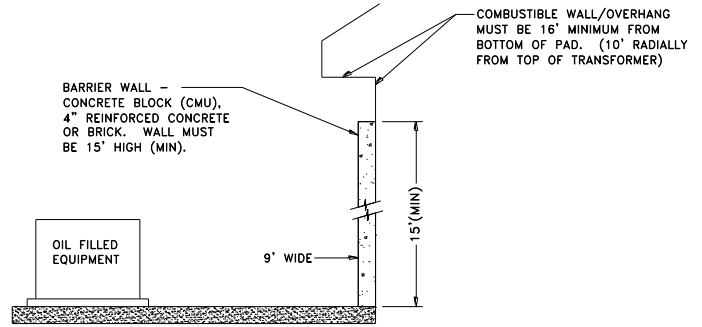

FIGURE 3A

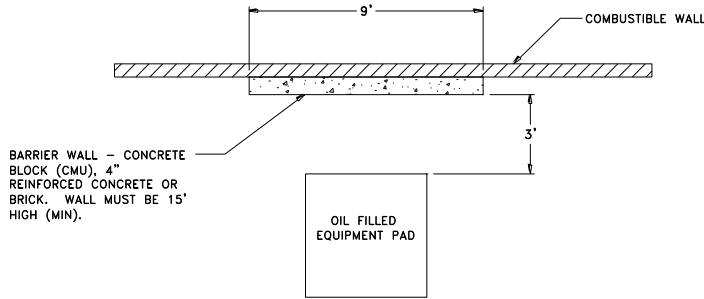

FIGURE 3B

				VOLUME 17 – ENGINEERING & CONSTRUCTION STANDARD		PE0010U
				PADMOUNTED EQUIPMENT LOCATIONS & CLEARANCES		
Drawn:	Eng:	Appr:	Date:			Revision: 6
JL	MB	DA	11/14			Page 4 of 5

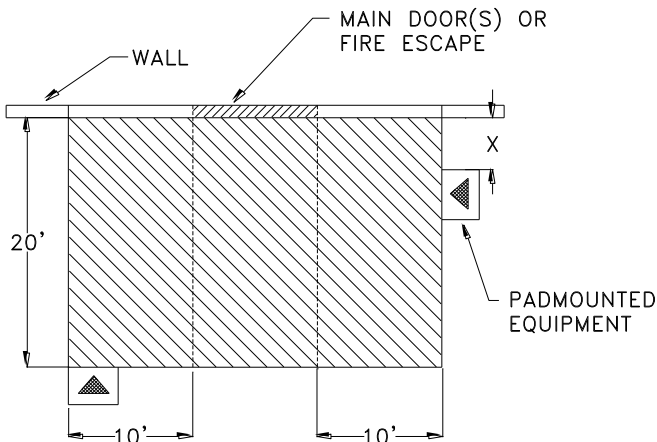

FIGURE 4
DOOR OR FIRE ESCAPE

PADMOUNTED OIL-FILLED EQUIPMENT SHALL NOT BE LOCATED WITHIN A ZONE EXTENDING 20 FT. OUTWARD OR 10 FT. TO EITHER SIDE OF A MAIN BUILDING DOOR OR FIRE ESCAPE.

NOTE: "MAIN DOOR(S)" - THOSE WHICH ARE THE NORMAL MEANS OF PEDESTRIAN ACCESS TO AND FROM THE BUILDING.

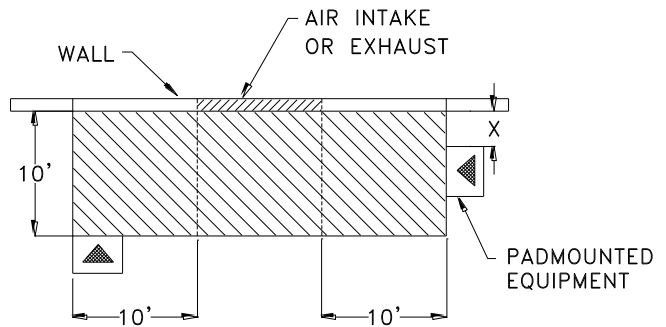

FIGURE 5
AIR INTAKE OR EXHAUST LOCATED LESS THAN 20' ABOVE THE EQUIPMENT

PADMOUNTED OIL-FILLED EQUIPMENT SHALL NOT BE LOCATED WITHIN A ZONE EXTENDING 10 FT. OUTWARD OR 10 FT. TO EITHER SIDE OF AN AIR INTAKE OR EXHAUST WHICH IS LOCATED LESS THAN 20 FT. ABOVE THE TOP OF THE EQUIPMENT.

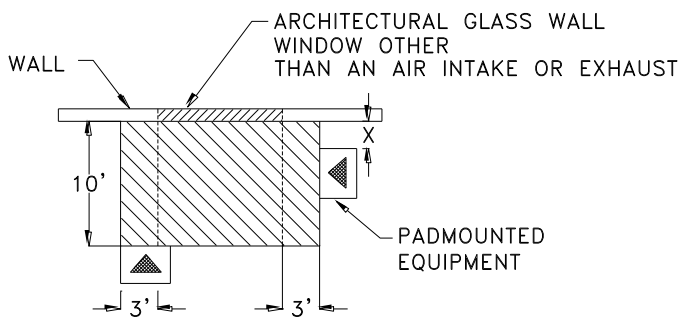

FIGURE 6
WINDOW OR OPENING (OTHER THAN AIR INTAKE OR EXHAUST) LOCATED LESS THAN 20' ABOVE THE EQUIPMENT

PADMOUNTED OIL-FILLED EQUIPMENT SHALL NOT BE LOCATED WITHIN A ZONE EXTENDING 10 FT. OUTWARD OR 3 FT. TO EITHER SIDE OF A BUILDING WINDOW OR OPENING (OTHER THAN AN AIR INTAKE) WHICH IS LOCATED LESS THAN 20 FT. ABOVE THE TOP OF THE EQUIPMENT.

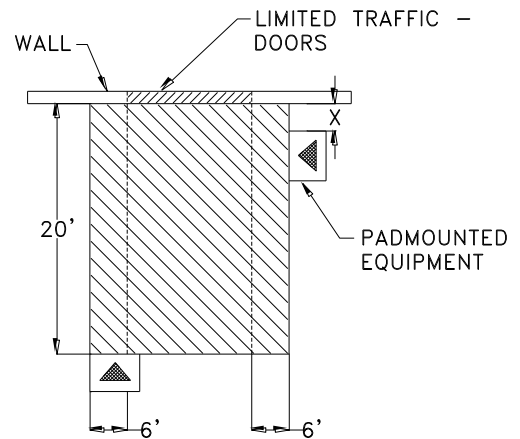

FIGURE 7
LIMITED PEDESTRIAN TRAFFIC DOORS OR GARAGE DOORS

PADMOUNTED OIL-FILLED EQUIPMENT SHALL NOT BE LOCATED WITHIN THE ZONES SHOWN ABOVE.

NOTE: X = MAX. PRACTICAL WITH MINIMUM BASIC CLEARANCES.

	VOLUME 17 - ENGINEERING & CONSTRUCTION STANDARD			PE0010U
	PADMOUNTED EQUIPMENT LOCATIONS & CLEARANCES			
Drawn:	Eng:	Appr:	Date:	Revision: 6
JL	MB	DA	11/14	Page 5 of 5