

NOTES:

- 1) LENGTH OF PUP TO BE SIX INCHES. SADDLE PUP TO FIT MAIN. DO NOT SADDLE VALVE END.
- 2) 4" PE3408 PIPE, STOCK ITEM #41-5060, LENGTH TO BE DETERMINED BY PLANNER.
- 3) STEEL RISER TO BE FIELD FABRICATED. LENGTH OF BASE TO APPROXIMATELY EQUAL LENGTH OF RISER.
- 4) ALL WIRE CONNECTIONS TO STEEL PIPE TO BE CADWELDED AND COATED WITH PRIMER, PROTECTO-WRAP AND TAPE. USE CALDWELD STOCK #47-0038 AND CALDWELD SLEEVE #47-0037.
- 5) TRACER WIRE, STOCK ITEM #45-7500, TO BE INSTALLED PER GAS CONSTRUCTION SPECIFICATIONS.
- 6) COAT ALL STEEL PIPE WITH PRIMER, PROTECTO-WRAP AND TAPE. COAT VALVE WITH MASTIC, EXCEPT FOR VALVE STEM.
- 7) TAPE TRACER WIRE TO ABOVE GROUND STEEL PORTION OF GAS SERVICE.

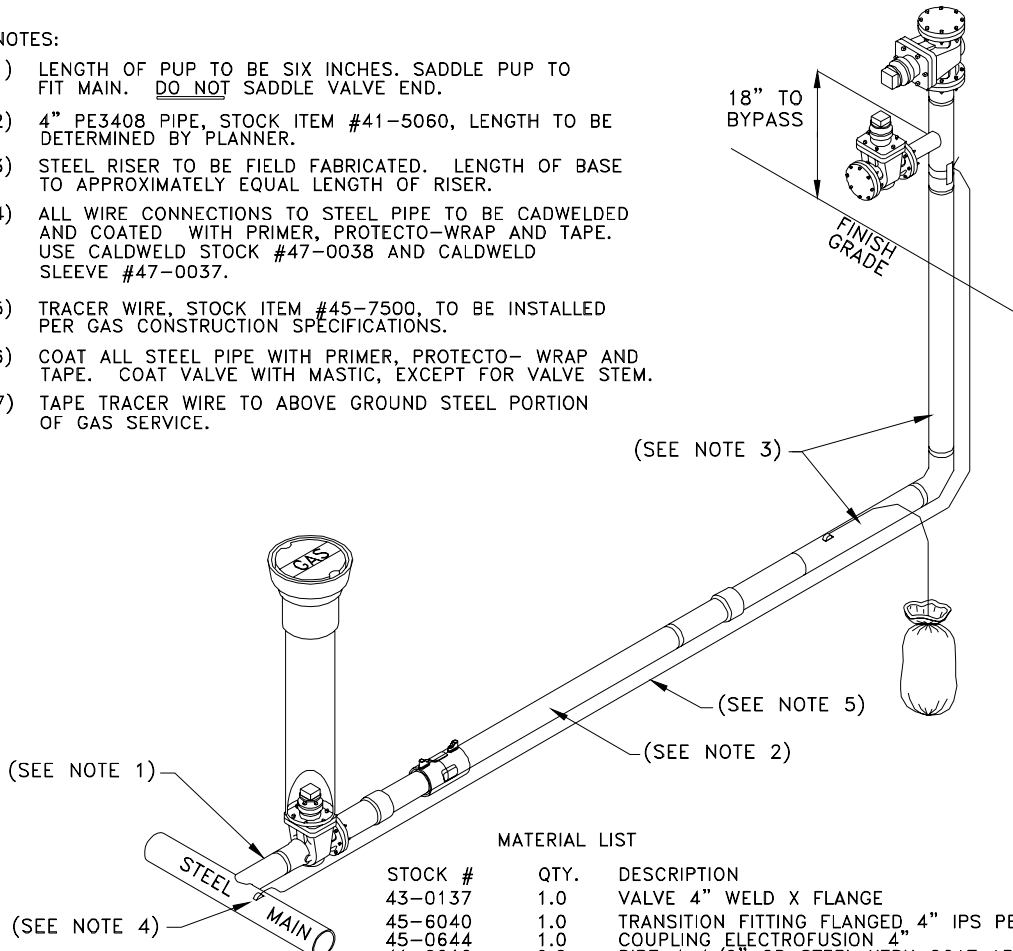

MATERIAL LIST

STOCK #	QTY.	DESCRIPTION
43-0137	1.0	VALVE 4" WELD X FLANGE
45-6040	1.0	TRANSITION FITTING FLANGED, 4" IPS PE3408
45-0644	1.0	COUPLING ELECTROFUSION 4"
41-0210	9.0	PIPE 4-1/2" OD STEEL XTRU COAT API5L GRADE B
47-0050	2.0	GASKET FULL FACE 4 IN.
47-0360	24.0	BOLT MACHINE 5/8" X 3" HEX HEAD W/HEX NUT
43-0010	1.0	BOX 6" VALVE CAST IRON
43-0095	1.0	COVER BOX VALVE GAS 6"
41-3000	3.0	PIPE PVC 6" SEWER 6.275 O.D. SDR 35 FOR VALVES
45-6020	1.0	TRANSITION FITTING 4" IPS PE3408
45-0930	1.0	ELBOW WELDING 90 DEGREE 4" STD RADIUS
45-2237	1.0	TEE REDUCING 4" X 4" X 2" WELDING
45-0990	1.0	FLANGE SLIP-ON WELDING 2"
43-0125	1.0	VALVE 2" FLANGED ENDS
45-0950	1.0	FLANGE BLIND 2"
45-1010	1.0	FLANGE SLIP-ON WELDING 4"
43-0135	1.0	VALVE 4" FLANGED ENDS
45-0960	1.0	FLANGE BLIND 4"
47-0070	1.0	INSULATION FLANGE KIT 2"
47-0080	1.0	INSULATION FLANGE KIT 4"
47-0040	1.0	GASKET FULL FACE 2 IN.
47-0340	8.0	BOLT MACHINE 5/8" X 2-1/2" HEX HEAD W/HEX NUT
47-0260	1.0	TAPE PROTECTO-WRAP 6 IN. X 50 FT.
47-0300	1.0	TAPE BLACK 2 IN. X 100 FT.
47-0182	0.5	MASTIC
47-0180	0.5	PRIMER
47-0020	1.0	ANODE MAGNESIUM 3 LB. WITH COVERING



ENGINEERING & CONSTRUCTION STANDARD
 SECTION 5 GAS CONSTRUCTION DRAWINGS
 SERVICE TAP INSTALLATIONS
 4" PE COMPLETE SERVICE
 OFF STEEL MAIN

SHEET 28 OF 33

DRAWING NUMBER
STI25G

DRAWN	DESIGN	SUPR	DATE	REV
KS	KS	HB	5/98	7/06