

Metering Equipment: Material Requirements

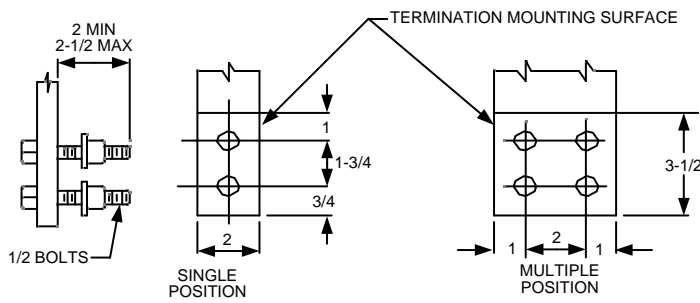

FIGURE 1
TERMINATING BOLT AND DRILLING
DETAIL OF TERMINATING FACILITIES

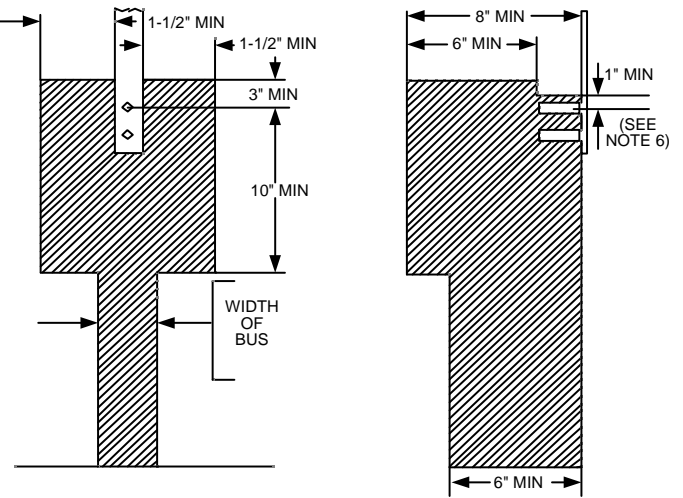

FIGURE 4
REQUIRED UNOBSTRUCTED WORKING
SPACE FOR ALL TERMINATIONS

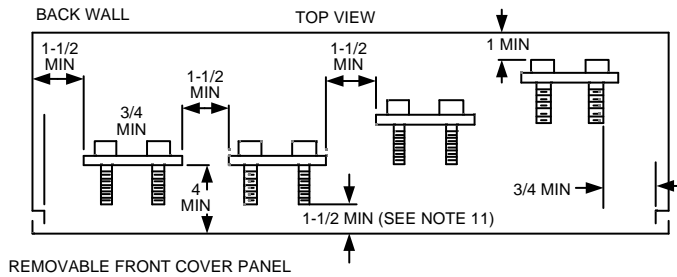

FIGURE 2
SPACING REQUIREMENTS FOR TERMINATING FACILITIES
(SIDE BY SIDE OR STAGGERED)

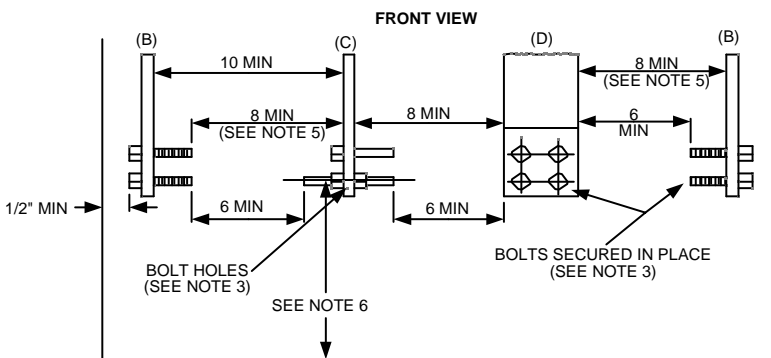

FIGURE 3
SPACING REQUIREMENTS FOR TERMINATING FACILITIES
ACCESSIBLE FROM (A) FRONT ONLY, (B) ONE SIDE ONLY,
OR (C) FROM EITHER SIDE (SEE NOTES 3 & 4)

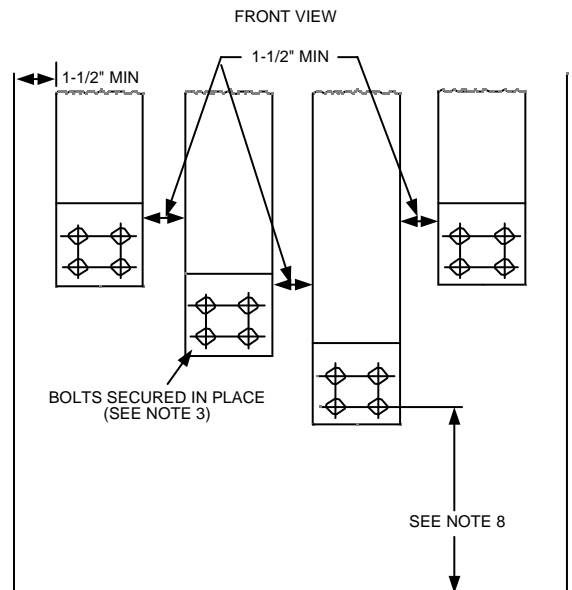

FIGURE 5
SPACING REQUIREMENTS FOR TOP TO BOTTOM
STAGGER OF TERMINATING FACILITIES

4 INCH MIN REQUIRED (ASSURE 1 INCH MINIMUM
CLEARANCE FROM BODY OF TERMINATING LUG
(WHEN IN PLACE) TO FRONT PANEL
SEE NOTES 4 & 5

NOTES:

- One landing position is required for each 400 amps (or portion thereof) of service ampacity up to 1200 (consult Metering Department for services exceeding 1200 amps). Each landing position shall consist of two 1/2" steel bolts spaced on 1-3/4" vertical centers and extending from 2" to 2-1/2" from the mounting surface. When multiple positions are required, provide a minimum of 2" of horizontal spacing between positions.

| | | | | | | |
|--------|------|-------|-------|--|--|---------------|
| | | | | Electric Service Requirements | | RPM-47 |
| | | | | Underground Service Terminating Facilities in Pull Boxes or Pull Sections | | |
| Drawn: | Eng: | Appr: | Date: | | | Revision: 1 |
| DH | DH | DA | 12/06 | | | Page 1 of 2 |

Metering Equipment: Material Requirements

Exception: Edgewise terminating facilities may consist of 9/16" holes having the same spacing as specified for the 1/2" bolts as specified above and in Figure 1. The unobstructed working space shall be provided on both sides of the termination bus (see Figure 3).

2. Each terminating bolt shall be provided with a spring washer and a nut. The spring washer may be either a cone-type (Belleville) washer or a split-ring washer and a flat washer. All parts shall be plated to prevent corrosion. Terminating bolts shall not be used to secure the termination bus in place.
3. Terminating bolts must be secured in place. "Secured in place" shall mean that the stud will not turn, back out, or loosen in any manner when tightening or loosening terminal nuts (including cross threaded situations).
4. In the terminal mounting area, which is defined as the area of the terminating facilities shown in Fig.1, a clear space (barrel of proximity) of 1-1/2" minimum is required around any terminating facility including its bolts and bolt heads, any other bus, any other terminating facility, or any grounded surface, except:
 - A. The minimum clearance to the back of the pull section may be reduced to 1".
 - B. The minimum clearance to any fully insulated horizontal bus behind the terminating facility may be reduced to 1".
 - C. The neutral terminating facility may have a minimum clearance of 1" from any grounded surface.
5. Each terminating facility shall have an unobstructed working space, accessible from the front of the pull section as viewed from the access compartment opening, in front of the entire mounting surface as shown in figure 4.

Exception: For terminating facilities with bolts facing the access opening as shown in Fig 2, the required 1-1/2" side clearance (bus to access opening return flange) may be reduced to 3/4".
6. The clearance directly above and measured from the center of the top termination bolt may be reduced to 1" to either an insulated surface or bus of the same potential.
7. No more than one termination facility may be mounted along any sidewall.
8. See RPM-2, RPM-3, RPM-42, RPM-43 and RPM-45 for the minimum distance from the lowest bolt on the termination facility to the bottom of the termination enclosure.
9. Terminating facilities shall be secured to prevent turning or bus misalignment when cables are installed.
10. Uninsulated busses of different potentials shall not be permitted below or behind any terminating position as viewed from the front of the pull section. If cross-bussing is installed below or behind a terminating position, the cross-bussing shall be fully insulated or barriered.
11. For switchboard pull sections, a 1-1/2" minimum dimension is permitted from an energized part to a removable access cover panel when a safety barrier is provided by the manufacturer. Where a safety barrier is not provided, the minimum clearance shall be increased to 4". For barrier requirements, see RPM-45, Note 8.

| | | | | | | |
|---|------|-------|-------|--|--|---------------|
|  | | | | Electric Service Requirements | | RPM-47 |
| | | | | Underground Service Terminating Facilities in Pull Boxes or Pull Sections | | |
| Drawn: | Eng: | Appr: | Date: | | | Revision: 1 |
| DH | DH | DA | 12/06 | | | Page 2 of 2 |