

Vaults and Boxes

DESIGN REQUIREMENTSPP

TOLERANCES:

a = +1", -1"
 b = +1/2", -1/2"
 c = +0", -1 1/2"

APPROVED STRUCTURE	
MANUFACTURER	MANHOLE
Jensen Precast	J-RS-97

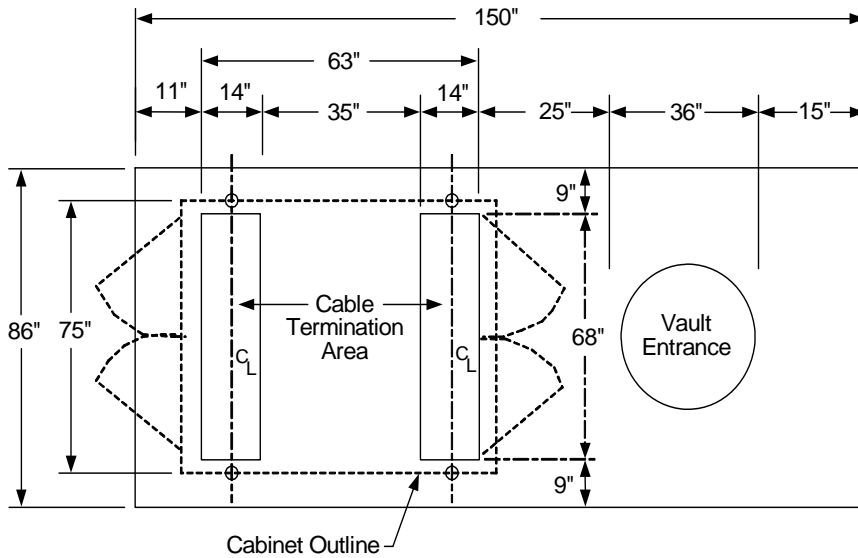

LEGEND:

1. Traffic lid & ring
2. Cable slot
3. 1/2"-13 UNC grounding inserts
4. Top section
5. Middle section
6. Bottom section
7. Molded knockout
8. Sump pump recess
9. Pulling eye
10. 4" conduit terminator
11. 6" conduit terminator
12. 1" PVC ground wire conduit

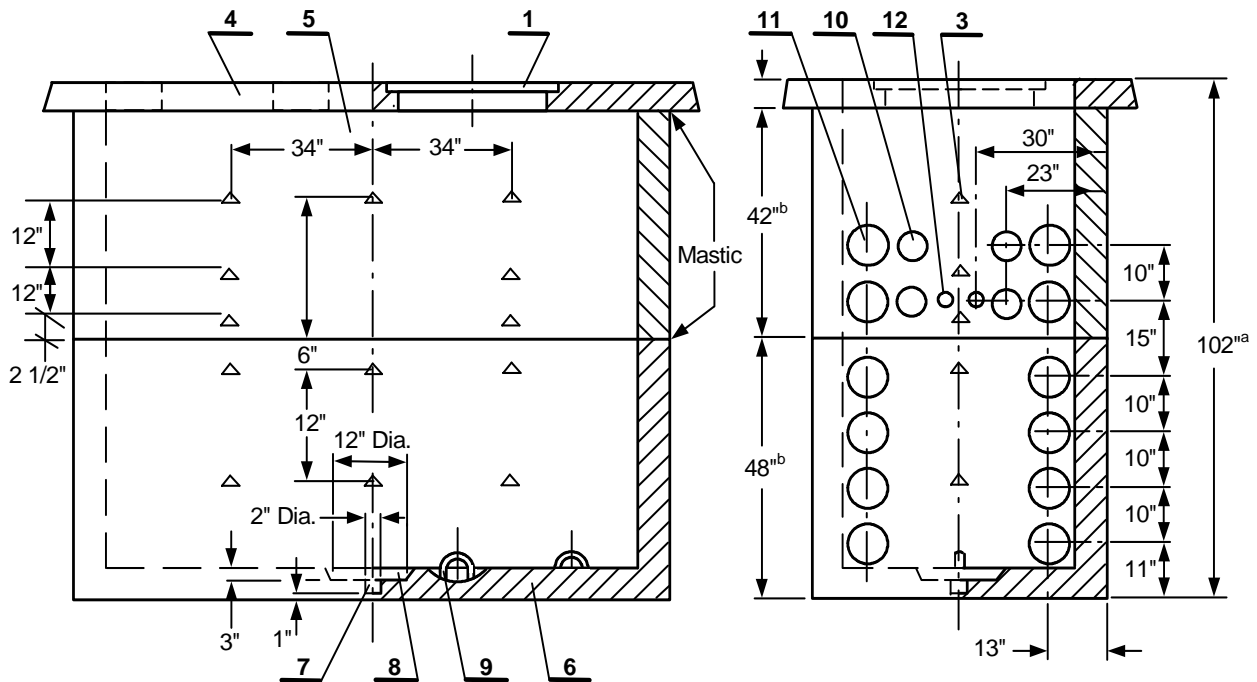

XX-XX MANHOLE
 ALL RS-98 TO RS-116

	Electric Service Requirement			RS-97
	Manhole: Switch/Fuse Cabinet, 15kV			
Drawn: KT Eng: RD Appr: DA Date: 10/16				Revision: 8 Page 1 of 5

Vaults and Boxes

1. Ring and Lid

1. All traffic rings and lids require NVE approval.
2. Traffic rings and lids shall be made in USA and meet AASHTO-H20.44 specification. Conform to H-20 wheel loading, ASTM A-48, and class 35B.
3. Lid shall have a 1" diameter lifting hole (through the thickness of the lid), located 9" to 12" from the center of the lid.
4. Lid shall have the word "ELECTRIC" in 1" letters, embossed in the top.
5. Lid shall be safely fastened to the ring with four 1/2"-13 UNC stainless steel pentahead bolts.
6. Frame to be reversible.
7. Ring and lid to have indexing provisions to assist with bolt-hole alignment.

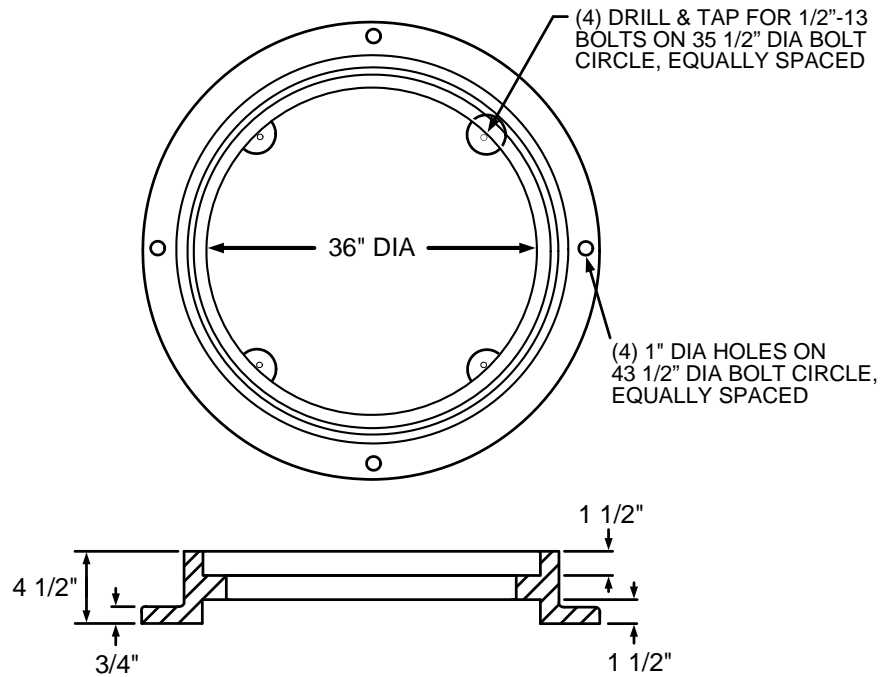

1. Top Pad Section

1. Two 14" x 68" cable slots.
2. One 1/2"-13 UNC insert.
3. 36" diameter cast iron traffic frame mounted in the concrete.

				Electric Service Requirement		RS-97
				Manhole: Switch/Fuse Cabinet, 15kV		
Drawn:	Eng:	Appr:	Date:			Revision: 8
KT	RD	DA	10/16			Page 2 of 5

Vaults and Boxes

2. Middle Section:

1. Nine 1/2" grounding insert nuts in each side wall and three steel insert nut in each end wall, located on the same level.
2. A 1" diameter PVC conduit through the end walls.
3. Four 6" and four 4" diameter PVC conduit terminators through each end wall.
4. 60" (W) x 126" (L) x 42" (H) inside dimensions with tolerances of ± 1 ".
5. Three 18" steel racks installed on each side wall and one on each end wall.

3. Bottom Section:

1. Six 1/2" grounding insert nuts in each side wall and two steel insert nuts in each end wall, located on two levels per drawing on page 1.
2. Six steel pulling eyes in the floor (hot dip galvanized).
3. A 12" diameter x 3" deep sump pump recess with a 2" diameter knockout in the middle of the floor.
4. Eight 6" diameter PVC conduit terminators through each end wall.
5. 60" (W) x 126" (L) x 42" (H) inside dimensions with tolerances of ± 1 ".
6. Three 40" steel racks installed on each side wall and one on each end wall.

4. Entire Structure:

1. Shall meet RS-G2 and RS-G4.

NOTE: In the case of road expansion, this structure shall not be adapted for placement under the road without NVE T & D Standards approval.

2. Shims of any type are not allowed for the installation of this box.

				Electric Service Requirement		RS-97
				Manhole: Switch/Fuse Cabinet, 15kV		
Drawn:	Eng:	Appr:	Date:	Revision: 8		
KT	RD	DA	10/16	Page 3 of 5		

Vaults and Boxes

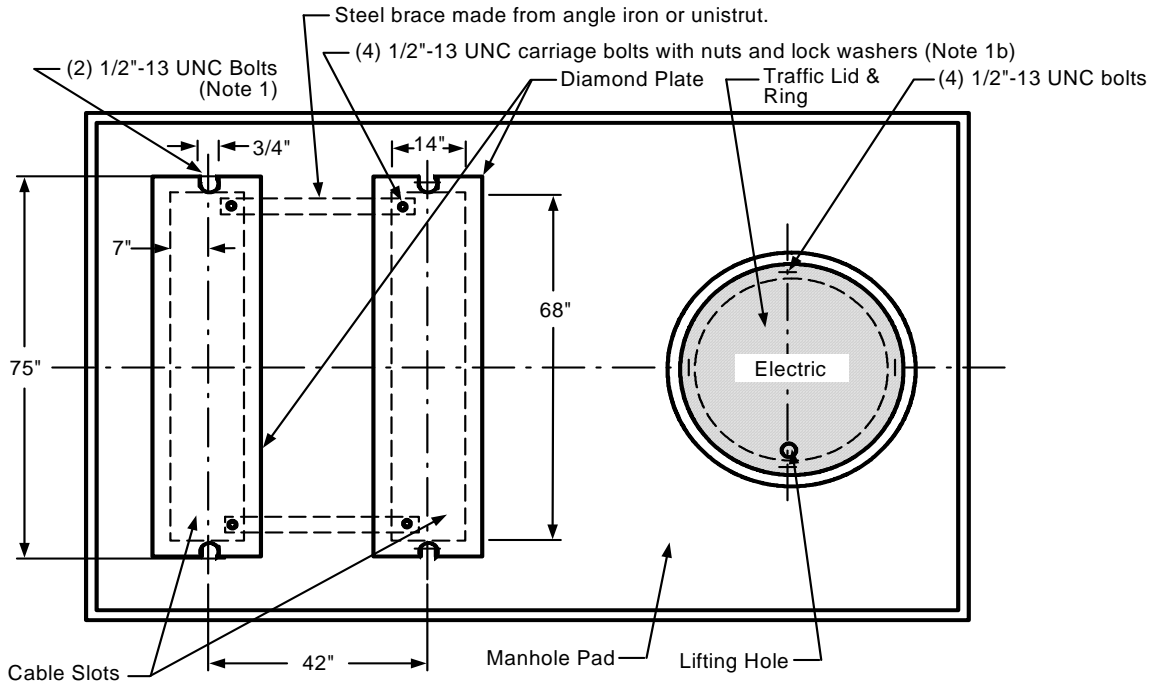

RS-97 MANHOLE
 ALL RSI-98 to RSI-116
 SAFETY REQUIREMENTS

5. Diamond Plates

1. Every Top Pad shall have both cable slots covered with 1/4" x 17" x 74" steel diamond plates per above drawing. Each plate shall be fastened to the pad with two 1/2" – 13UNC hex head bolts on opposite sides per above drawing.
2. Removal of the Steel Diamond Plate without immediate installation of the Cabinet is prohibited.

6. Grounding

Manholes shall have grounding inserts on all walls around the inside perimeter as shown on Page 1. The inserts shall be spaced in accordance with this specification drawing. Inserts to be attached to the internal manhole rebar by spot welding or approved connector. The insert shall accept 1/2" American Standard thread. Continuity between all inserts installed in manhole sections shall be checked and verified prior to shipping by manufacturer/supplier.

				Electric Service Requirement		RS-97
				Manhole: Switch/Fuse Cabinet, 15kV		
Drawn:	Eng:	Appr:	Date:			Revision: 8
KT	RD	DA	10/16			Page 4 of 5

THIS PAGE INTENTIONALLY LEFT BLANK

				Electric Service Requirement		RS-97
				Manhole: Switch/Fuse Cabinet, 15kV		
Drawn:	Eng:	Appr:	Date:	Revision: 8		
KT	RD	DA	10/16	Page 5 of 5		