



# Installation Guide

## NEED HELP?

For assistance with installation, please visit

[nvenergy.com/powershift/selfinstallguide](http://nvenergy.com/powershift/selfinstallguide)

or call PowerShift Customer Care at

**855-676-9373**

### INCLUDED POWERSHIFT EQUIPMENT & MATERIALS

- PowerShift Smart Thermostat
- Wiring labels
- 2 Phillip head screws
- 2 plastic wall anchors
- Gateway device
- Gateway power cable
- Ethernet cable

## Important Safety Message



Your safety is very important. Care should be taken to review and completely understand the installation instructions before installing and wiring the PowerShift thermostat.

A basic understanding of electrical and HVAC systems is required to properly install this thermostat. If you have difficulty following the directions, you should not proceed. Please call Customer Care to schedule a professional installation.

By selecting the self installation option, it is the users responsibility to ensure that the thermostat is installed safely and properly. NV Energy will not be liable for any damages caused by failure to comply with the installation instructions.

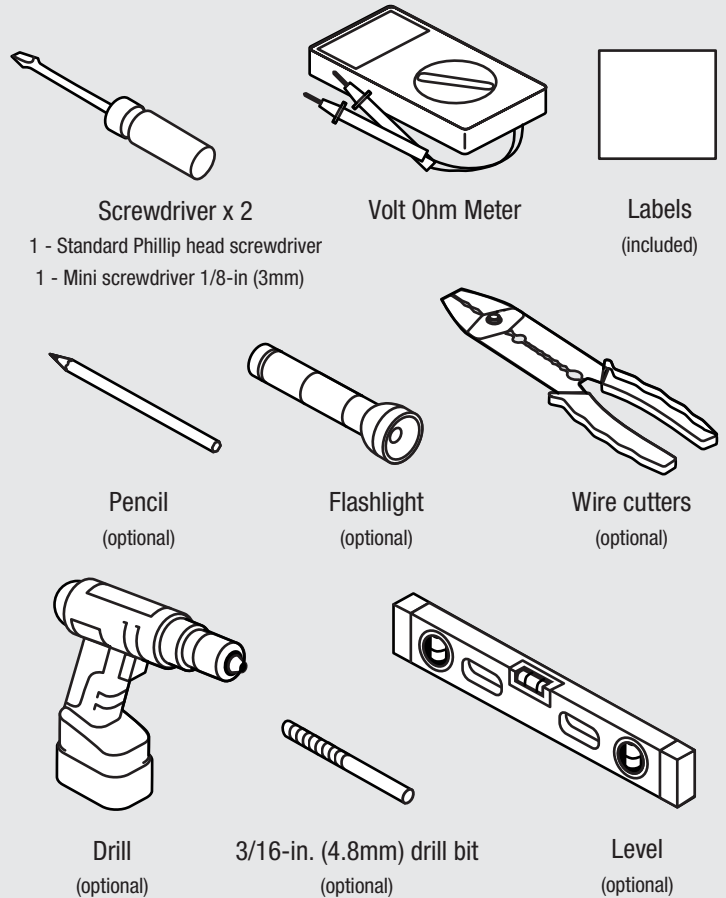

## GETTING STARTED

The PowerShift Smart Thermostat requires a 24 Volt AC (24 VAC) Common Wire (C/X Wire) to supply power. If your existing thermostat is not powered by 24 VAC, you may have to connect the Common Wire at the HVAC unit. Follow the instructions below to determine if your home has the required 24 VAC Common Wire.

**Determine if your current system is using 24VAC Common Wire**

- Remove the existing thermostat cover from the wall plate (refer to your thermostat manual if necessary)

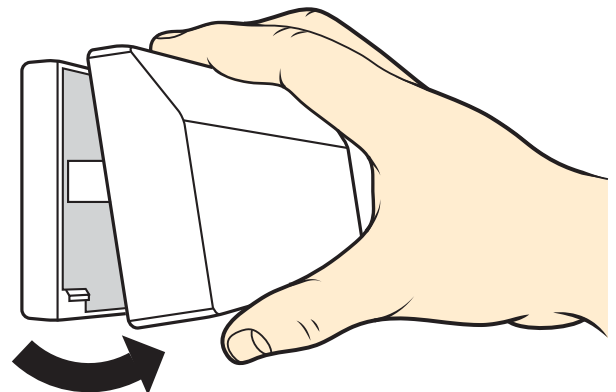

- Visually inspect wire terminals to locate terminals “C or X” and “R,” “RH” or “RC”
- Determine if the Common Wire (typically blue wire, but not always) is present and connected to the C terminal:
  - If Common Wire is connected to C or X terminal, you likely have 24 VAC power available
  - If your thermostat does not have a Common Wire connected to C or X terminal or if you have unused wires in the thermostat wire bundle, test the voltage of unused wires (typically blue wire) to determine if there is 24 VAC power available
- Using a volt meter, touch one voltmeter lead to the metal screw of the C or X terminal and the other lead to R, RH, or RC terminal.
  - Voltage readings of around 24V (between 24 to 30 VAC) means there is power available at the C terminal – proceed to Step 1 to remove your old thermostat
  - Voltage readings of around 0V (below 18 VAC) means the Common Wire is not connected – visit [nvenergy.com/powershift/selfinstallguide](http://nvenergy.com/powershift/selfinstallguide) for additional instructions on how to connect the 24VAC Common Wire at the HVAC unit
  - If you can't identify the Common Wire, please visit [nvenergy.com/powershift/selfinstallguide](http://nvenergy.com/powershift/selfinstallguide) for further instructions.

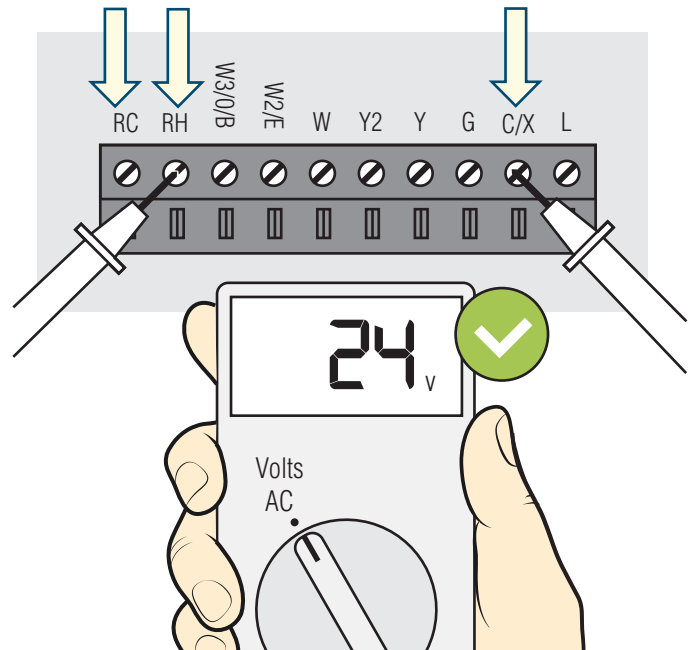
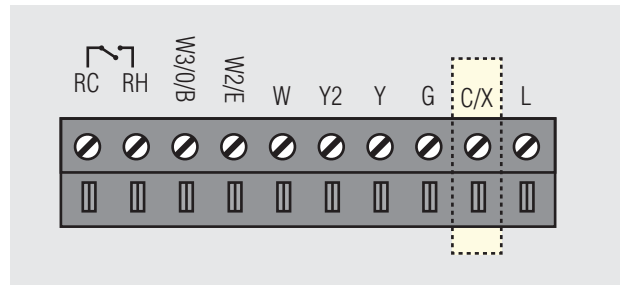

**If you determine that the C/X Wire is not connected and are not comfortable proceeding, please call 855-676-9373 to schedule a professional installation.**

## STEP 1 REMOVE OLD THERMOSTAT

**Turn off electricity to the HVAC system**

### ⚠ CAUTION

It is important to verify there is no voltage at the wall.

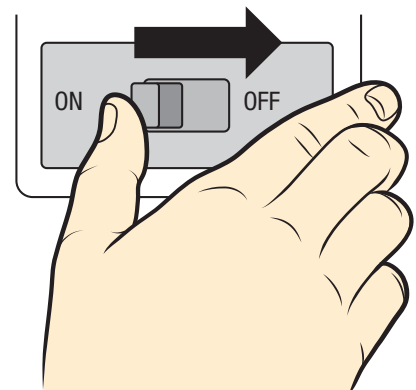

- Switch OFF power to heating and cooling equipment Locate correct breaker(s); typically labeled A/C, FAU, or HVAC. No voltage should be present at the thermostat
  - Confirm using a volt meter, touch one voltmeter lead to the metal screw of the C or X terminal and the other lead to R, RH, or RC terminal.
  - Voltage readings of around 24V means incorrect breaker has been turned off. Switch OFF main breaker

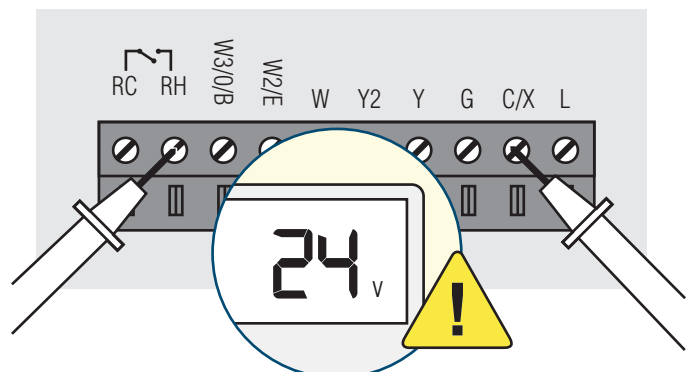

## Label Wires to match terminal name

### CAUTION

DO NOT remove wires from existing thermostat until each wire is labeled. There is no standard color code. Ignore the color of the wires and label according to the terminal each wire is connected to.

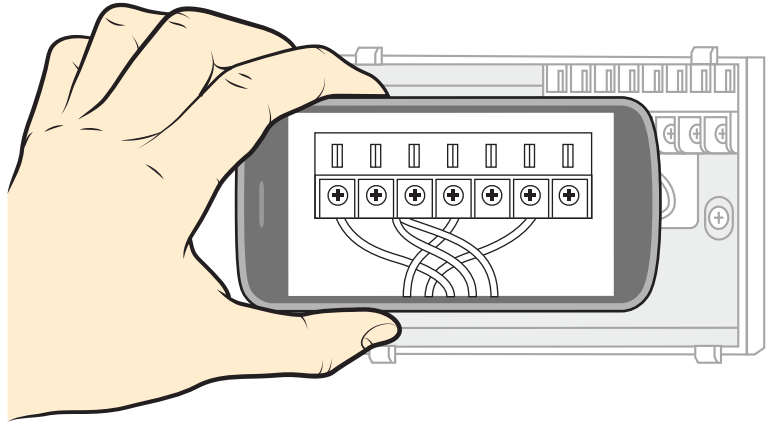

### Wire Labels (included)

C/X	C/X	W	W
G	G	W2/E	W2/E
Y	Y	W3/O/B	W3/O/B
Y2	Y2	RC/RH	RC/RH

- Take a picture of your existing thermostat base plate with wires still connected to the wall plate or make a note of which wires are connected to which terminal. Keep this with your old thermostat in case you need to replace in the future.
- Locate wire labels provided in box with the new PowerShift thermostat
- Identify and attach labels to each wire of your existing thermostat according to the terminal it is screwed into. Make sure all your wires labeled before proceeding
- If you had to connect a new 24 VAC common wire, you will use the "C/X" label on that wire

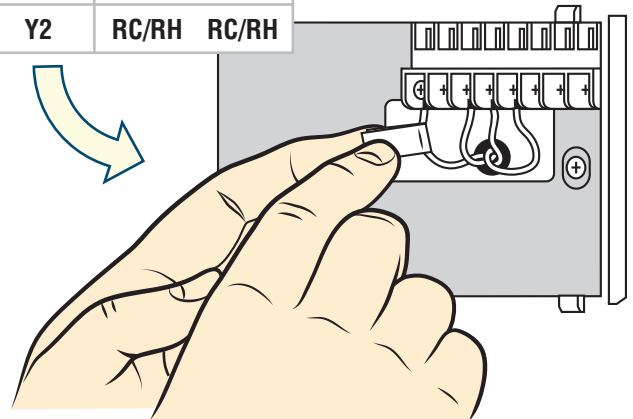

## Disconnect and remove your old thermostat from the wall

- Depending on the style of your thermostat, use a screwdriver, loosen screws of wire terminals once labeled and disconnect wires from the wall plate
- Remove all screws attaching the wall plate to the wall and remove wall plate. Make sure the wires do not slip back into the wall

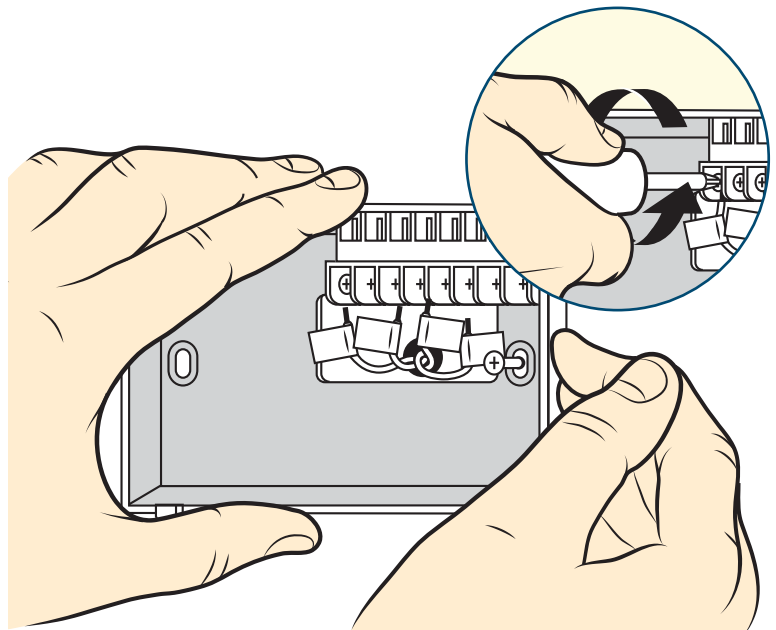

## STEP 2 INSTALL POWERSHIFT SMART THERMOSTAT

### Mount PowerShift wall plate

- Separate faceplate and wall plate of the PowerShift thermostat by pulling straight off
- Hold the thermostat base plate against the wall, with the wires coming through the center opening, above terminal block.
- Mount wallplate to wall with hardware provided. Use level and drill with 3/16 in. drill bit if necessary

**A beauty plate may be required to cover any visible holes from previous thermostat. Contact 855-676-9373 to request beauty plate, if needed before beginning installation.**

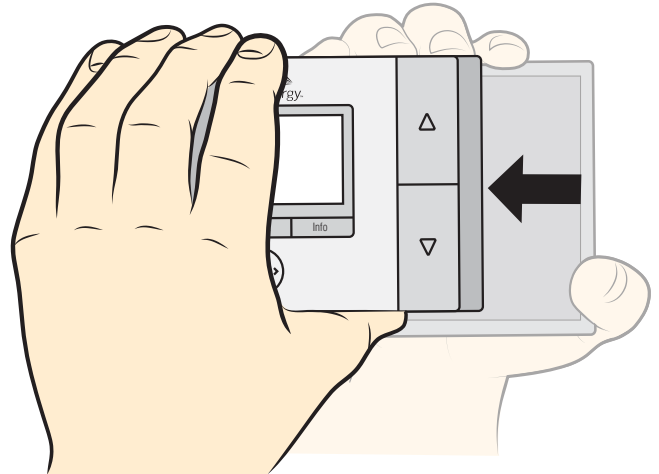

### Connect Wires to matching terminal

- Insert the thermostat wires from the wall through the opening in the PowerShift thermostat wallplate. Connect exposed end of correct wires to matching screw terminals as labeled in Step 1
- Tighten the terminal screw until each wire is secure enough to lightly pull on without coming loose. Do not over-tighten, this may cut the wire.

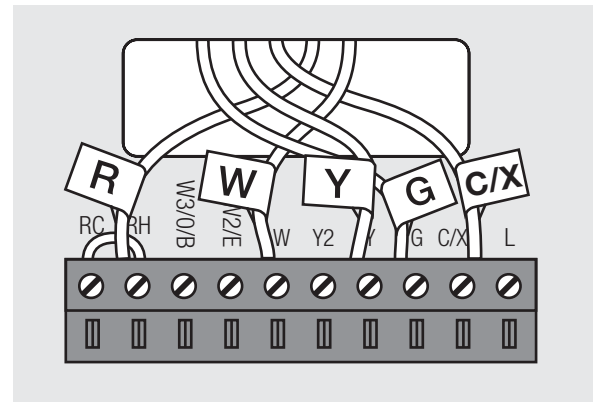

### ⚠ IMPORTANT

If you have just single R wire, you can use either RH or RC terminal and leave the wire jumper-clip in place. If you have separate wires labeled RH and RC at the wall you need to remove the wire jumper-clip between these 2 terminals on the PowerShift thermostat wallplate.

### ⚠ IMPORTANT

For Heat Pump Configurations

If you have O/B wire, you must check wire information on Terminal Reference page 8.

### Attach thermostat faceplate & turn on electricity to HVAC system

- Attach thermostat faceplate to wallplate by snapping into place. You may need to gently push wire bundle against wall to attach the faceplate properly

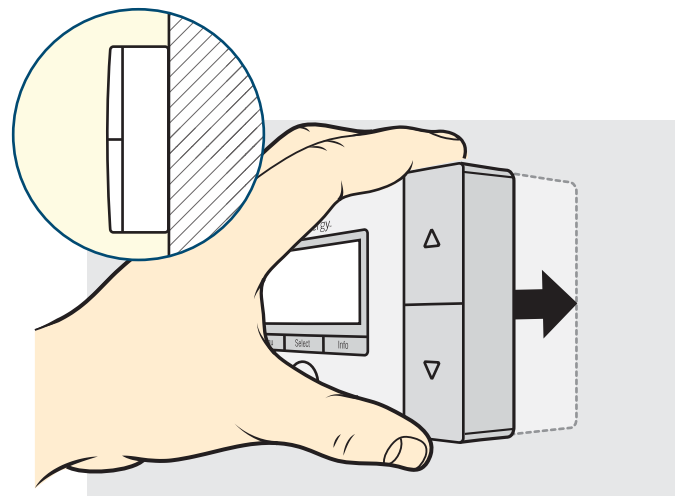

- With all the wires connected (including the C/X wire), and the thermostat securely attached to the wall, it is time to turn the AC power back on. Turn the breaker to the ON position at the breaker panel.

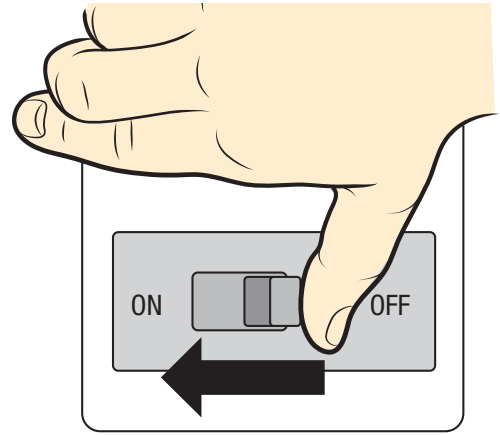

### STEP 3 CONNECT POWERSHIFT GATEWAY

The PowerShift gateway device must be connected to your Internet router to enable the PowerShift system to work properly.

- A Connect the provided Ethernet cable between the gateway Ethernet port and any available port of your home router.
- B Connect the provided 5VDC power supply between the gateway and a 120 VAC power source that will always stay powered on.

#### Startup sequence

After plugging in the device the three LEDs at the top of gateway will gradually turn solid green.

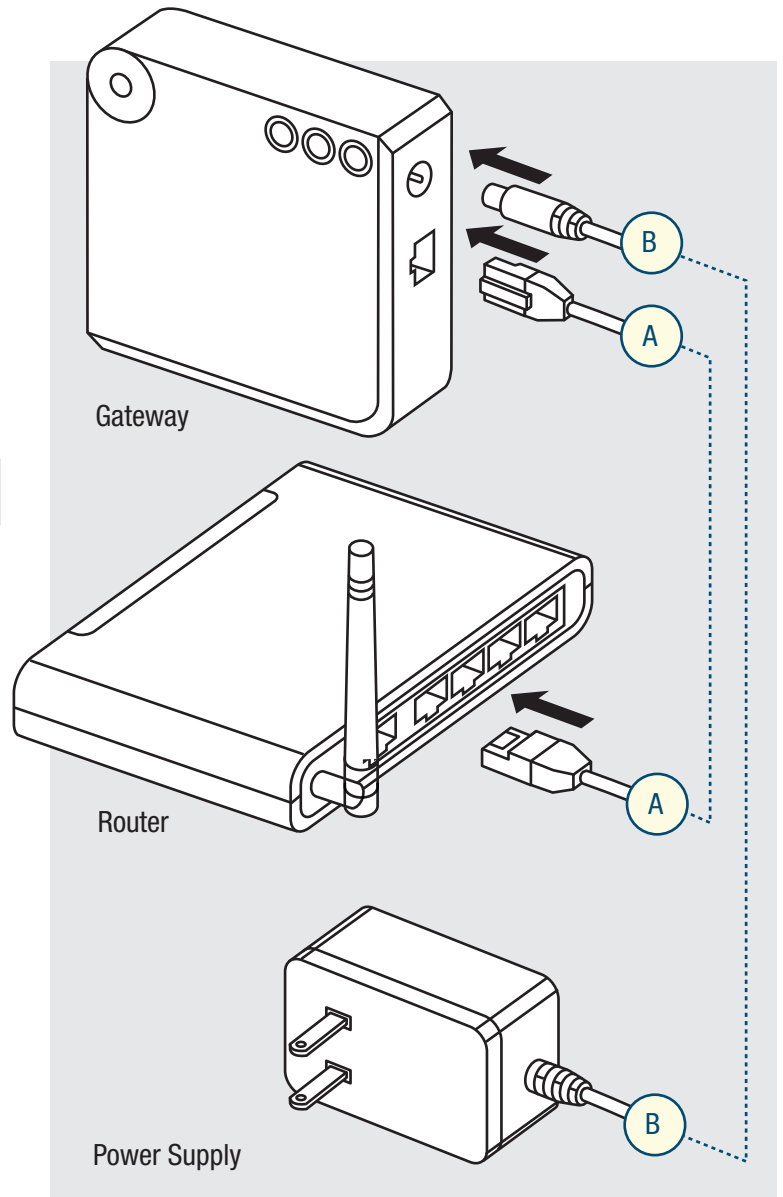
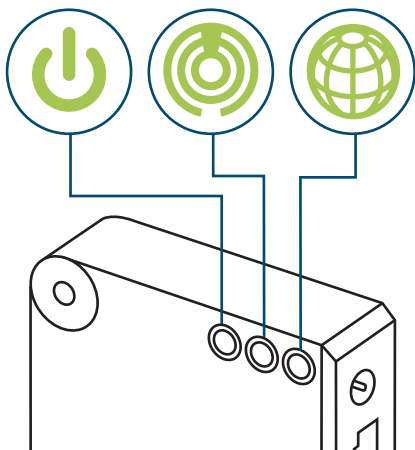

## STEP 4 CHECK HVAC & TEST THERMOSTAT

### Check that power is available to the thermostat

- The PowerShift thermostat display will show the date, time, HVAC mode, indoor temperature and setpoint if powered on. Pressing any button will activate the screen.

If power is not evident, check for the following:

- The Forced Air Unit/FAU breaker is turned back to the ON position. To reset the breaker if tripped, turn the breaker to the OFF position, then back to the ON position
- Check that the correct 24VAC wires are connected to the RC/RH and C terminals

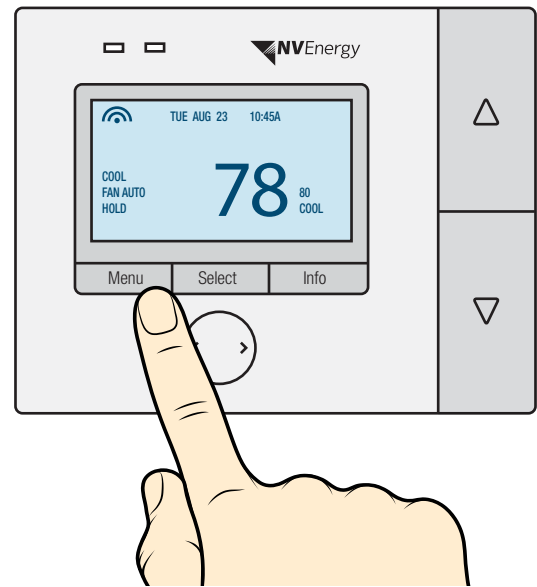

### Test the thermostat cooling mode

- To activate cooling mode on the PowerShift thermostat, turn to cooling mode by pressing Menu->Mode->Cool.
- On the home screen, press the down arrow until the cool setpoint is a few degrees lower than the indoor temperature.
- Wait for the system to turn on, which could take up to 5 minutes.
- Once the system is on, check any air vent for cool air coming out.
- Once cooling system is confirmed to be functioning, adjust to desired setpoint close to the indoor temperature.
- Your PowerShift thermostat will run on a default Cooling temperature program until you activate your account through the PowerShift portal.

### CAUTION

**Important - DO NOT test cooling mode if outside temperature is below 50 degrees F.**

### Test the thermostat heating mode

- To activate heating mode on the PowerShift thermostat, turn to heating mode by pressing Menu->Mode->Heat.
- On the home screen, press the up arrow until the heat setpoint is a few degrees higher than the indoor temperature.
- Wait for the system to turn on, which could take up to 5 minutes.
- Once the system is on, check any air vent for warm air coming out.
- Once heating system is confirmed to be functioning, adjust to desired setpoint close to the indoor temperature.
- Your PowerShift thermostat will run on a default Heating temperature program until you activate your account through the PowerShift portal.

Congratulations, you have successfully installed your PowerShift system!





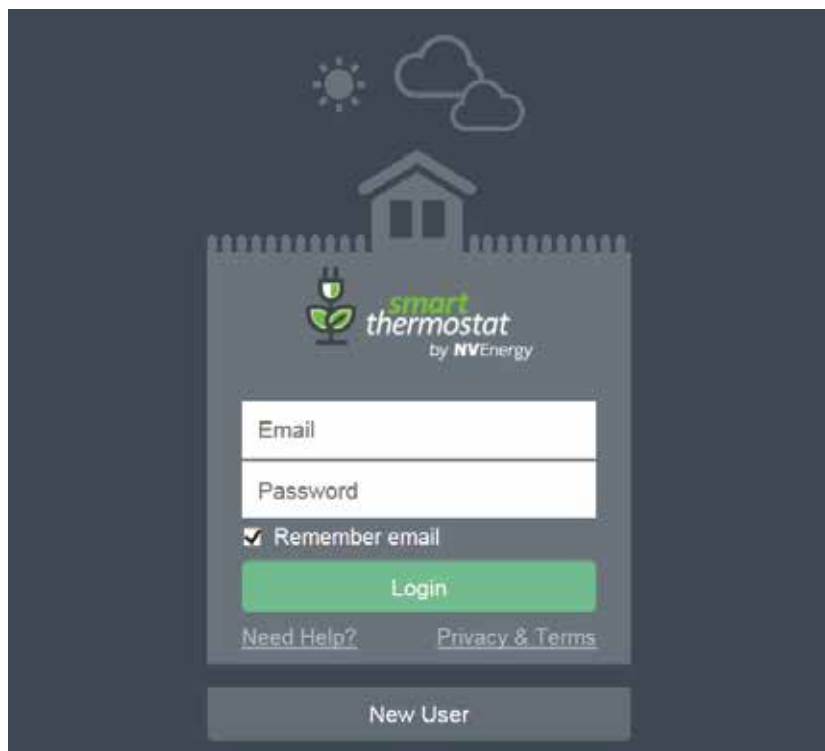





### Start using your PowerShift Smart Thermostat

- 1 Activate your PowerShift account online at [nve.ecofactor.com](http://nve.ecofactor.com)



- 2 Create customized temperature schedules and program your thermostat
- 3 Download mobile app for your smart phone to access your thermostat and adjust settings from anywhere
- 4 Communicate with your thermostat by making adjustments to suit your comfort preferences (the system will continually learn from the adjustments you make).
- 5 Watch your savings add up (it may take up to one month for savings report data to appear in the portal)

## Terminal definition

		Terminal	Conventional Heat Cool system	Heat Pump System
L		L	No use	System monitor
C/X		C/X	24VAC common for control circuit and thermostat power input	
G		G	Fan	Fan
Y		Y	1 <sup>st</sup> stage cooling	1 <sup>st</sup> stage compressor
Y2		Y2	2 <sup>nd</sup> stage cooling	2 <sup>nd</sup> stage compressor
W		W	1 <sup>st</sup> stage heating	Auxiliary heating
W2/E		W2/E	2 <sup>nd</sup> stage heating	Emergency heating
W3/O/B		W3/O/B	3 <sup>rd</sup> stage heating	Changeover valve
RH		RH	24VAC Power supply for Heating side	
RC		RC	24VAC Power supply for Cooling side	