



BID PROTOCOL
Fall 2020
RENEWABLE ENERGY
REQUEST FOR PROPOSALS

Issued: October 27, 2020
Responses Due: January 6, 2021
4:00 p.m. Pacific Prevailing Time (“PPT”)

Bid Event Website: <https://berkshirehathawayenergy.app.jaggaer.com>

Table of Contents

1.0 Overview.....	1
1.1 Purpose and Scope	1
1.2 General Renewable Energy Resource Types and Commercial Structures	2
1.3 Energy Storage Systems	3
1.4 Acceptable RFP Products	3
2.0 General Information for the 2020 Fall RE RFP.....	5
2.1 General Information.....	5
2.2 RFP Schedule.....	6
2.3 Registration.....	7
2.4 Contact Information, Questions, and Answers	7
2.5 Proposal Submittal Instructions	8
2.6 Bid Fee.....	8
2.7 Minimum Eligibility Requirements for Bidders.....	10
2.8 Proposal for PPA with and without ESS (Product 2 and Product 4)	13
2.9 Proposal for Asset Purchase Agreement (Product 1A and Product 1B).....	14
2.10 ESS System APA (Product 1C).....	15
2.11 Proposal for Build Transfer Agreement (Products 3A, 3B and 3C).....	15
2.12 No NV Energy Security; Approvals	17
2.13 Performance and Reliability Standards.....	18
3.0 Submittal Preparation Instructions.....	18
3.1 Part One of Proposal	20
3.1.1 Cover Letter	20
3.1.2 Bidder Information.....	21
3.2 Part Two of Proposal	24
3.2.1 Proposal Executive Summary	24
3.2.2 Technical Information.....	24
3.2.3 Interconnection	32
3.2.4 Resource Supply	34
3.2.5 Assurance of Generating Equipment Supply.....	36
3.2.6 Project Execution Plan.....	36
3.2.7 Contract Terms and Conditions	40
3.2.8 Other Information	40
3.3 Bid Numbering and File Naming Convention	41

4.0 Standards of Conduct.....42

5.0 Evaluation Procedures and Criteria42

 5.1 First Stage: Development of Initial Shortlists.....43

 5.1.1 Price Factor Evaluation (up to 60%).....44

 5.1.2 Non-Price Factor (up to 30%).....45

 5.1.3 Economic Benefits Factor (up to 10%).....46

 5.2 Second Stage: Best and Final Pricing.....47

 5.2.1 The Final Shortlist.....47

 5.3 Final Selection of Proposal(s).....48

6.0 Awarding of Contracts.....48

7.0 Post-Bid Negotiations49

Attachments

Attachment A – Confidentiality Agreement

Attachment B – Voluntary Consent Form

Attachment C – Pro Forma Power Purchase Agreement and Exhibits

Attachment D – Pro Forma Asset Purchase Agreement and Exhibits

Attachment E – Pro Forma Build Transfer Agreement and Exhibits

Attachment F – Pro Forma O&M Term Sheet

Attachment G – Proposal Input Forms

Attachment H – Bidder Proposal Compliance Checklist

Attachment I – Nevada Administrative Code 704 Requirements

Attachment J – Bidder’s Safety Plan

Attachment K – Approved Vendors List

Attachment L – Reserved

Attachment M – Reserved

Attachment N – Form of Work Site Agreement

Attachment O – Metering Scheme Examples

Attachment P – Proposal Zip File Structure

1.0 OVERVIEW

1.1 Purpose and Scope

Sierra Pacific Power Company d/b/a NV Energy (“SPPC”) and Nevada Power Company d/b/a NV Energy (“NPC”), collectively referred to as (“NV Energy” or the “Company”) are issuing this 2020 fall renewable energy request for proposals (“2020 Fall RE RFP” or “RFP”) to interested parties with the intent of securing proposals for the acquisition of long-term dispatchable renewable energy resources with a minimum size of 20 MW together with all associated environmental and renewable energy attributes.¹

With this RFP, NV Energy seeks to advance State of Nevada energy policies by procuring new renewable energy projects that produce economic, health and environmental benefits for Nevadans.² Renewable energy solidifies the foundation upon which safe, reliable, reasonably priced electric service can be delivered to NV Energy’s customers. The renewable resources sought in this RFP will help the Companies to meet the increases in the renewable portfolio standard established by Senate Bill 358, and to meet the needs of a diverse group of stakeholders and policy objectives. Specifically, NV Energy seeks to:

- continue progress towards the 2050 goal of energy production from zero carbon dioxide emission resources equal to the total amount of electricity sold in the State;³
- provide lower cost energy and capacity;
- provide customer price stability;
- respond to customer demands for more renewable energy;
- provide for long-term resource adequacy and reliability of Nevada’s electric system.

This RFP also will accept proposals for grid-tied energy storage projects that connect to NV Energy’s system. Such energy storage systems (“ESS”) are sought to help manage the increased penetration of intermittent renewables on NV Energy’s system.

¹ MW refers to the megawatts of capacity at the point of delivery, alternating current.

² Senate Bill 358, 2019 Session of Nevada Legislature, §8(2).

³ Ibid., 2

This bid protocol document sets forth the terms, conditions and directives for the 2020 Fall RE RFP. By responding to this RFP, Bidder agrees to be bound by all the terms, conditions, and other requirements stated in the RFP, including any modifications made to it by NV Energy prior to Bidder's submission of its proposal(s). Bidders will be notified of any such modifications prior to the proposal submission deadline.

1.2 General Renewable Energy Resource Types and Commercial Structures

NV Energy will consider qualified proposals from Bidders who currently own or have legally binding (e.g. deed, lease agreement, lease option agreement) rights to develop acceptable renewable energy generating resources (including associated substation, transmission lines, water and gas lines, and telecommunication systems, as applicable) with a minimum net power production capacity of 20 MW. Bidders are required to provide proposals for renewable energy together with all associated environmental and renewable energy attributes as a bundled product, in accordance with this RFP bid protocol document. The Company will not consider demand side, energy efficiency, distributed generation, or portfolio energy credit ("PC")-only proposals.

This 2020 Fall RE RFP is applicable to the purchase of electrical energy from qualifying renewable energy facilities as defined in Nevada Revised Statutes ("NRS") Sections 704.7315, 704.7811 and 704.7815, and pursuant to Nevada Administrative Code ("NAC") Sections 704.8831 through 704.8893. NV Energy is seeking proposals that are compliant with existing Nevada renewable portfolio standards and that provide resource diversification at competitive prices. As described in greater detail below, the Company will consider proposals based on a variety of structures and resource types.

Under this RFP, acceptable renewable energy resource types include solar, geothermal, wind, biomass, and biogas technologies. Acceptable commercial structures for long-term renewable energy resources include asset purchase agreements ("APA") for existing renewable energy resources, build transfer agreements ("BTA") for projects in development and power purchase agreements ("PPA"); however, for geothermal (flash and binary), biomass and biogas technologies NV Energy is only accepting PPA bids, all other technologies must bid APA or BTA (acceptable commercial structures are further defined in Table 1 below). Certain pro forma

agreements relating to acceptable commercial structures for qualifying renewable energy resource types are included as attachments to this RFP bid protocol document.

The 2020 Fall RE RFP requires that projects be capable of delivering energy to serve load in the Company's retail service territory (<http://www.oasis.oati.com/NEVP/>).

1.3 Energy Storage Systems

NV Energy will consider supplemental energy storage systems ("ESS") that are eligible for the Investment Tax Credit ("ITC") and that are associated with Bidder's proposed renewable energy resource.

For ESS proposed along with a new renewable resource, Bidder shall size an AC-coupled ESS such that its AC capacity at the point of delivery is 70 percent that of the renewable resource proposed, with a 4-hour duration, however, Bidders may propose additional ESS designs.

Stand-alone ESS proposals must have a capacity to energy ratio of one to four, a minimum capacity of 20MW at the point of delivery, and designed for three hundred and sixty five (365) equivalent cycles per year.⁴ For purposes of this RFP, ESS systems are not considered a renewable energy resource or a generating facility.⁵

1.4 Acceptable RFP Products

NV Energy is seeking the following products and commercial structures (Table 1), located in Nevada, as outlined in more detail in Sections 2.8 through 2.11 below:⁶

⁴ For example, a 50MW energy storage facility would be able to provide 200MWh in four hours to the point of delivery. Bidders may include in their proposals other ESS capacity and duration ratios however for the purposes of scoring and ranking bids, only the ratios above will be evaluated.

⁵ An ESS may be considered a generating facility for other purposes such as for transmission interconnection studies.

⁶ See Section 2.7 g for exception for wind energy

Table 1 – RFP Products

Product	A	B	C
	Commercial Structure	Renewable + Storage ^{a, f}	Storage Only ^b
Existing Generating Facility:^c			
1	APA ^d	X	X
2	PPA (non-solar photovoltaic) ^g	X	
New Project:			
3	BTA ^{d, e}	X	X
4	PPA (non-solar photovoltaic) ^g	X	

Table Notes:

- ^a All renewable energy must include unencumbered PCs.
- ^b NV Energy will consider minimum capacities as stated above with a one to four power to energy (MW:MWh) ratio for energy storage options.
- ^c Proposed projects must not be currently contracted with NV Energy, unless contract expires on or before commercial operation date deadline.
- ^d Only solar, solar with energy storage, wind, or wind with energy storage structures will be considered. Note that the pro forma agreements attached as Attachments D and E are tailored for specific technologies and structures; conforming changes will be required for alternative technologies/structures.
- ^e Proposed projects must be constructed to NV Energy engineering, procurement and construction (“EPC”) standards
- ^f The Large Generator Interconnection Agreement may require action by Bidder to add energy storage. Energy storage dispatch, when paired with renewable energy generation, must not exceed the interconnection agreement’s capacity.
- ^g Only geothermal (flash and binary), biomass and biogas technologies will be considered.

Bidders are invited to submit multiple proposals, incorporating combinations of the products and commercial structures that allow for cost savings. Bidders of solar and wind projects are encouraged to include ESS in their proposals.

Renewable energy resources and ESS system options must be integrated into the NV Energy system as a network resource for serving load in NV Energy’s balancing authority area. **Proposals must allow for a commercial operation date on or before December 31, 2025.** Proposals must have a point of delivery already identified, and able to interconnect to NV Energy’s transmission system. Bidders must demonstrate, through documentation of the completed process

milestones that a Facilities Study has been completed and that a Large Generator Interconnection Agreement (“LGIA”) is in place or will be in place that supports the proposed commercial operation date.⁷

For Bidders submitting PPA proposals for acceptable renewable energy resource, the term will be for fifteen (15) years and/or twenty-five (25) years. PPA proposals must include purchase options in favor of NV Energy for the renewable energy resource, including all energy, capacity and associated environmental and renewable energy attributes, which options are exercisable: (a) at the eighth, fourteenth, and twentieth (if applicable) years following the commercial operation date of the renewable energy resource, and (b) at the end of the term of the PPA. PUCN approval may be required prior to NV Energy exercising such purchase option.

2.0 GENERAL INFORMATION FOR THE 2020 FALL RE RFP

2.1 General Information

NV Energy is seeking proposals for resources as set forth in Section 1.1 of this RFP. NV Energy will evaluate the proposals based on pricing as well as other criteria, including: (a) the greatest economic benefit to the State of Nevada; (b) the greatest opportunity for the creation of new jobs in the State of Nevada; (c) the best value to NV Energy’s customers; (d) the financial stability of the Bidder and the ability of the Bidder to financially back the proposal and any warranty or production guarantee; and (e) conformance to the bid criteria and form agreements. NV Energy may select one proposal, multiple proposals or no proposals at all as a result of this RFP.

All proposals submitted to NV Energy pursuant to this RFP become the property of NV Energy and may be used by NV Energy as it deems appropriate. As part of the RFP process, Bidder is required to sign a Confidentiality Agreement in the form provided in Attachment A to this RFP. However, Bidders shall have no expectation of confidential treatment of the executed agreement(s) which will be submitted to the PUCN and become available to the public. NV Energy will only consider as confidential those portions of a Bidder’s proposal clearly marked “Proprietary and Confidential.” Bidders should only mark information as proprietary and confidential that is

⁷ An LGIA is applicable to facilities with a net generating facility capacity of greater than 20 MW.

actually proprietary and confidential. NV Energy will evaluate such marked information and determine, in its discretion, whether or not the information should be deemed as proprietary and confidential.

A proposal may be subject to discovery and disclosure in regulatory or judicial proceedings, including those initiated by a party other than NV Energy. Bidders may be required to justify the requested confidential treatment under the provisions of a protective order issued in such a proceeding. NV Energy may disclose proprietary and confidential information in the course of such proceeding without further notice to Bidders as required by law. If required by an order of the PUCN or any other governmental authority, NV Energy may provide the confidential information without prior consultation or notice to Bidders. Such information may also be made available under applicable state or federal laws to regulatory commission(s), their staff(s), and other governmental authorities having an interest or jurisdiction in these matters without further notice to Bidder. The Company also reserves the right to release such information to any contractors for the purpose of providing technical expertise to the Company.

Bidders will be required to submit bids electronically to the Company using BHE JAGGAER, which is accessible via <https://berkshirehathawayenergy.app.jaggaer.com>⁸. Bidders are expected to provide a response in each data field represented. The “free text” data field accepts responses that are approximately 1,000 characters. In these fields, Bidders should avoid special formatting and characters, as these can inflate the character count unnecessarily and result in a saving error. In this instance Bidders should simply remove any special characters and formatting, or shorten the answer to save successfully. Bidders should also fill out Excel spreadsheets and provide attachments, to the extent requested by the Company.

2.2 RFP Schedule

NV Energy has established the target schedule for this RFP as shown in Table 2 below. NV Energy reserves the right to amend the target schedule at any time.

⁸ To gain access to the event, bidders must first register their organization in the Berkshire Hathaway Energy JAGGAER Advantage platform (“BHE JAGGAER”). See directives on RFP website.

Table 2 – RFP Schedule

RFP Event	Target Schedule
Launch RFP	October 27, 2020
Bidder Questions Deadline (1pm)	December 31, 2020
Bids Due (4pm)	January 6, 2021
Bid Fees Postmark Deadline	January 8, 2021
Initial Shortlist Issued	February 5, 2021
Best and Final Pricing Due	February 8, 2021
Final Shortlist Issued	February 22, 2021
Contract Negotiations Conclude	April 27, 2021
Execution of Contract(s)	April 30, 2021
PUCN Filing for Approval	June 1, 2021
PUCN Approval Timeline (up to 210 Days)	December 28, 2021
Commercial Operation Achieved On or Before	December 31, 2025

2.3 Registration

All parties interested in submitting a bid in response to this RFP must complete and submit a Bidders Registration and Contact Information Form located on the website for this RFP, which can be accessed at www.nvenergy.com/RFPFall2020. Bid numbers will be self-assigned as directed under Section 3.3. Parties registering for this RFP must include both a primary and alternate point of contact and identify one lead negotiator from your organization who will be available to discuss any questions specific to your proposal. This information should be entered in the Corporate Information tab/worksheet of Attachment G.

2.4 Contact Information, Questions, and Answers

This RFP can be accessed at <https://berkshirehathawayenergy.app.jaggaer.com>. *All communications between Bidders and NV Energy regarding this RFP will be done using BHE JAGGAER as the messaging system.* Communication through this system will be monitored by the Company. Communications with NV Energy personnel regarding this RFP outside of the BHE

JAGGAER system is grounds to disqualify a Bidder's submission. Any response submitted by mail, facsimile, or email **will not be accepted**. Pre-bidding questions submitted by Bidders, and Company responses, will be posted in BHE JAGGAER for all Bidders to view. At any time during the RFP, a Bidder may log into <https://berkshirehathawayenergy.app.jaggaer.com>, download the communications, complete the online datasheet information and upload responses. NV Energy requires that all questions concerning this RFP be submitted no later than 1:00 p.m. (PPT) December 31, 2020. Questions submitted after this time may not receive a response.

2.5 Proposal Submittal Instructions

Submitted proposals must be organized in the manner described in Section 3.0 of this RFP and signed by a representative of Bidder who is duly authorized to submit the offer contained in the proposal on behalf of Bidder. Each proposal should specify the self-assigned bid number (see Section 3.3).

Bidders will be required to submit both parts of the proposal (as detailed in Section 3.0) through BHE JAGGAER. Part One of Bidder's proposal, as detailed in Section 3.1 below, will be utilized by NV Energy's credit group in completing a credit review of each Bidder.

In order to consistently analyze responses to this RFP, Bidders are required to prepare their submission within the outlined format. Responses not complying with the format requirements may be considered non-conforming and may be disqualified at the discretion of the Company.

For a proposal to be considered by NV Energy, the proposal must be fully uploaded into BHE JAGGAER by 4:00 p.m. (PPT) on January 6, 2021. Proposals, or parts thereof, received after 4:00 p.m. (PPT) on January 6, 2021, will not be accepted. Bidders are strongly encouraged to complete forms and begin uploading files hours in advance of the deadline.

2.6 Bid Fee

Each Bidder must submit the required Bid Fee(s) to NV Energy, by certified check or cashier's check made payable to "Nevada Power Company d/b/a NV Energy" (for projects in southern Nevada) or "Sierra Pacific Power Company d/b/a NV Energy" (for projects in northern Nevada) at the address listed below. The check must reference the 2020 Fall RE RFP and Bidder's bid number(s). The aggregate Bid Fee (as determined below) for each Bidder must be postmarked (or date stamped by delivery service provider) within two (2) business days of submitting the

proposal(s) in BHE JAGGAER. Bidder's proposal(s) will not be considered if Bidder fails to submit timely the required Bid Fee(s).

Address for Delivery of Bid Fee:

NV Energy
Renewable Energy & Origination (Bid Fee Processing)
Mail Stop B13RE
P.O. Box 98910
Las Vegas, Nevada 89151-0001

OR

NV Energy
Renewable Energy & Origination (Bid Fee Processing)
Mail Stop B13RE
7155 S. Lindell Road
Las Vegas, NV 89118

The required amount of the Bid Fee for each Proposal is as follows:

- (1) \$10,000 for each proposal⁹; and
- (2) \$2,500 each, for up to two additional pricing options.

If Bidder is proposing a PPA, pricing is required for both a 15-year term and a 25-year term. This requirement for two term options does not require an additional bid fee. In this case, and at Bidder's discretion, Bidder may submit two pricing options under each of the term options at no additional cost.

For a bid fee adder of \$2,500 for each option, PPA bidders may propose up to two (2) additional pricing options for a single project. Those alternatives may include changes in pricing escalators, or equipment (e.g. different panels), with all other terms of the proposal being identical under the same base fee. Alternative project sizing and more than two additional pricing options will be considered separate proposals and require a separate bid fee.¹⁰

⁹ Different pricing options (e.g. fixed, escalating) are not considered separate proposals for bid fee calculation.

¹⁰ For a \$10,000 bid fee, bidders may submit up to two pricing options for each of the required term length options. Pricing options would be fixed or escalating prices, or due to alternate equipment (e.g. different solar panels), but all other terms of the proposal must be identical. In addition, for a fee of \$2500 per option, bidders may propose up to two (2) additional pricing options for the same proposal. If a bidder takes full advantage, under a single project/proposal, they would have 2 pricing options for each required term length (i.e. 4 pricing options), plus two additional pricing options for a total of 6 pricing options with a bid fee of \$15,000.

A separate Attachment G must be submitted for each pricing option. Data contained in Attachment G includes cost model inputs. Model outputs are used to aid in determining the project shortlist. Pricing options included within the proposal, but not in an Attachment G will not be considered. If a ESS system is proposed along with a new renewable energy resource, include both in one Attachment G. Follow the proposal numbering and file naming convention in Section 3.3 of this RFP bid protocol document (e.g., the proposal number for the initial Attachment G would be 1.0, and the second pricing option for the same proposal would be 1.1).

The Bid Fees will be used to cover the costs incurred by NV Energy in analyzing the proposals, including the costs of any consultants. Any such costs that are not covered by the Bid Fees will be recovered through fees assessed on Bidders of successful proposals (the “Success Fees”). The Success Fees will be determined by NV Energy once the final amount of Bid Fees and Company costs are known, provided that in no event will a Success Fee exceed \$250,000 per successful proposal. **THE BID FEE IS NON-REFUNDABLE. AFTER SUBMISSION OF BIDDER’S PROPOSAL, THE BID FEE WILL NOT BE REFUNDED UNLESS THE PROPOSAL IS WITHDRAWN PRIOR TO THE SUBMITTAL DUE DATE, THE PROPOSAL DOES NOT MEET THE MINIMUM ELIGIBILITY REQUIREMENTS AND THAT DEFICIENCY CANNOT BE CURED, OR THE PROPOSAL IS REJECTED FOR ANY OTHER NON-CONFORMANCE PRIOR TO COMMENCEMENT OF THE SHORTLISTING ANALYSES.**

2.7 Minimum Eligibility Requirements for Bidders

In addition to meeting the proposal organization requirements in Section 3.0, all Bidders must comply with certain minimum eligibility requirements to have their proposals considered in this RFP. Failure to meet the requirements of bulleted items a) through m) will result in rejection of the proposal. Further, any proposal may be deemed non-conforming, and may be rejected by NV Energy, as a result of items n) through ff) of the following:

Given the example provided, so long as all other terms of the proposal are identical (i.e. no differences in contract provisions, no change in project size, no change in Delivered Amount as defined in the PPA or as provided in 12x24 or 8760 values of Attachment G, no changes to metering configuration, etc.), Bidder would pay \$10,000. A change in battery coupling technology is a significant facility design change as opposed to a vendor or minor specification change, requiring additional due diligence and the change impacts some PPA terms and PPA exhibits therefore that would require a separate \$10,000 bid fee.

Minimum Requirements

- a) Failure to submit the full proposal in BHE JAGGAER by the due date and time, except where failure was caused by a technical issue with BHE JAGGAER.
- b) Failure to provide bid fee(s) by the deadline specified in RFP Schedule (Table 2).
- c) Proposal has failed to specify all pricing terms, and include them in Attachment G.
- d) Failure to permit disclosure of information contained in the proposal to (i) NV Energy's employees, contractors, consultants, agents or representatives, (ii) relevant regulatory authorities and other governmental authorities, or (iii) non-bidding parties that are party to regulatory proceedings, under appropriate confidentiality agreements.
- e) Failure to provide an official Facilities Study or LGIA issued by the NV Energy transmission provider.
- f) Bidder fails to demonstrate adequate site control for the proposed project, including access to the site, as evidenced through an executed and legally binding title, lease agreement, lease-option agreement, right-of-way, or easement issued by the fee owner or the applicable state or federal land resource agency.
- g) Project is not physically located in the state of Nevada – exception for wind energy proposals which may be located outside Nevada but must have transmission rights delivering energy and associated PCs to NV Energy's balancing authority area.
- h) Any attempt to influence NV Energy in the evaluation of the proposals outside the solicitation process.
- i) Any failure to disclose the real parties of interest in the proposal submitted.
- j) Collusive bidding or any other anticompetitive behavior or conduct.
- k) Bidder or project being bid is subject to bankruptcy or other insolvency-related proceedings.
- l) Failure to provide a copy of Bidder's executed Voluntary Consent Form, as submitted directly to the transmission provider, in the form provided in Attachment B of this RFP.
- m) Any proposal, under a partnership arrangement, that does not include evidence documenting that the partnership is legal and binding with an effective period that extends well beyond the expected contract execution date stated in Table 1 (RFP Schedule).

Additional Requirements

- n) Any of Bidder, its proposed prime contractor, or any material subcontractor has an Occupational Safety and Health Administration recordable incident rate greater than 1.5 in the last five (5) years or has had any fatalities on projects in the last three (3) years. Please provide relevant supporting documentation.
- o) Bidder, or any affiliate of Bidder, either (i) is in current litigation or arbitration with NV Energy or an affiliate of NV Energy, (ii) has, in writing, threatened litigation against NV Energy or an affiliate of NV Energy, with the threatened dispute having an amount in controversy in excess of one million dollars, or (iii) is currently adverse to

- NV Energy in any material regulatory proceeding before the PUCN or any other governmental authority, without regard to the amount in controversy.
- p) Bidder fails to address satisfactorily both the price and non-price factors, as discussed in more detail in Section 5 of this RFP.
 - q) Failure of Bidder's authorized officer to sign the proposal.
 - r) Any matter materially impairing Bidder, its proposed prime contractor, any major subcontractor or the project itself, including any matters impairing the output of the generating resource or its energy or environmental attributes.
 - s) Failure to adhere to Approved Vendors List (Attachment K).
 - t) For wind: failure to provide one year of viable wind data utilizing at least two anemometers for any wind project to support capacity factors submitted and failure to provide a third party wind study or equivalent to support the expected capacity factor of the project.
 - u) For geothermal: failure to provide a minimum of one production well and one injection well flow results to support the viability and capacity of the geothermal resource.
 - v) For solar: failure to provide Tier 1 solar panel manufacturer resource and technology along with a third party resource assessment report (i.e. PVSyst) to support the expected capacity factor.
 - w) For biomass: failure to provide a letter of intent with a biomass fuel source for a period of ten (10) years or greater along with a third party resource assessment report supporting the expected capacity factor.
 - x) For biogas: failure to provide a resource assessment report supporting the expected capacity factor. Report to include at a minimum, history of landfill, total volume permitted, volume filled, estimated closure date, organic fraction of the municipal solid waste, moisture levels, temperature and pH of the waste, future waste receipt, increase or decrease and average rainfall in the area.
 - y) For ESS systems: failure to demonstrate qualification for the ITC, failure to meet all requirements identified in Table 1, failure to identify the renewable energy resource, or failure to provide detailed description of required shared facilities and/or equipment with the associated renewable energy project (ESS-only proposals).
 - z) Failure to provide evidence of adequate development rights, including water rights and associated calculations demonstrating adequate water requirements, permits and information regarding water sources and well systems to support construction and operational phases for each resource. Bidders will also provide all executed contracts or other such documentation (example, water transmission plans, private transactional documents to support the required water rights, etc.).
 - aa) Failure to identify any and all shared facilities and/or equipment with a third party or under a separate agreement.
 - bb) For APA or BTA: failure to provide cash flow values required during the development, construction, and operations phase for each resource, including, with respect to build transfer agreements, values and schedules for the EPC Agreement and O&M

- Agreement. Or completion of cash flow table (Price Input tab) and Financial Inputs tab, both in Attachment G.
- cc) Failure to submit an acceptance of the applicable pro forma agreement(s) as written, or a comprehensive mark-up, including comments and revisions, to the applicable pro forma agreement(s) and related exhibits. See Section 3.2.7 for further information.
 - dd) Failure to submit “audited” financial statements and footnotes, including cash flow statements, for prior three (3) years. If Bidder does not have audited financials, Bidder must provide equivalent financials or the audited financials of the nearest level parent company.
 - ee) Failure to complete Attachment G in its entirety for each bid and pricing option.
 - ff) Failure to comply with or satisfy any other requirements specified in this RFP or any attachments hereto, including any requirements in connection with the pro forma agreements and any exhibits thereto.

Evaluation of proposals will follow the process discussed in Section 5. Evaluations to determine the final shortlist of Bidders are targeted to be completed as specified in Section 2.2. NV Energy may choose to engage the final shortlist of Bidders in further discussions and negotiations. Any such discussion or negotiation may be terminated by NV Energy at any time for any reason.

2.8 Proposal for PPA with and without ESS (Product 2 and Product 4)

NV Energy will consider qualifying proposals to enter into PPA for renewable energy resources and renewable energy resources with ESS in accordance with the requirements of Table 1 and in the form attached as Attachment C to this RFP.

Any proposed PPA for renewable energy resources shall have a term of fifteen (15) or twenty-five (25) full contract years. Bids shall include pricing for the renewable dispatchable facility. Products 2A and 4A are for renewable geothermal (flash or binary), biomass or biogas resources that do not include ESS and are priced with a single dollar per megawatt-hour. Product 2B and 4B are for renewable geothermal (flash or binary), biomass or biogas resources with a dollar per megawatt-hour energy price and ESS with a dollar per megawatt-month price.

Bidder’s proposal must contain the required documentation listed in Attachment G and any proposed changes to the pro forma PPA (Attachment C) in Microsoft Word format. Bidder’s proposal must also contain documentation of the completed process milestones, including demonstrating that a LGIA is in place or will be in place that allows for the proposed commercial

operation date of the renewable energy resource. For purposes of this RFP, in determining the Levelized Cost of Energy (“LCOE”) of the proposed renewable energy resource, NV Energy will include the transmission and distribution network upgrade costs identified in the LGIA that are to be borne by NV Energy. These costs are to be included in Attachment G. Transmission system losses and One Nevada transmission line available capacity may be considered for both feasibility and pricing evaluations.

Project development security, if applicable, and operating security will be required from Bidders based on the nameplate capacity of the renewable energy and/or ESS resource, as applicable, contained in Bidder’s proposal(s). Project development security amounts and operating security amounts are non-negotiable. The project development security, if applicable, shall be due within the number of days set forth in the PPA after countersignature of the PPA by NV Energy. The operating security shall be due and payable on the earlier of (a) the commercial operation date of the renewable energy resource and (b) countersignature of the PPA by NV Energy (if the renewable energy resource is then in commercial operation).

Any proposal made for the sale of renewable energy and associated environmental and renewable energy attributes, or the sale of capacity from an ESS system, must be made by Bidder with the understanding that the pro forma PPA attached as Attachment C to this RFP will be the basis for any definitive agreement between Bidder and NV Energy, and the proposal pricing must reflect the terms and conditions as set forth in the pro forma PPA.

2.9 Proposal for Asset Purchase Agreement (Product 1A and Product 1B)

NV Energy will consider qualifying proposals to enter into asset purchase agreements (“APAs”) for the sale of existing renewable energy resources, excluding geothermal (flash or binary), biomass and biogas, in accordance with the requirements of Table 1 and in the form attached as Attachment D to this RFP. Bidders should note the requirement in Table 1 that any renewable energy resource proposed by a Bidder under this category must not be currently contracted with NV Energy. Bidder’s proposal must contain the required documentation listed in Attachment G and any proposed changes to the pro forma APA (Attachment D) in Microsoft Word format. Bidder shall demonstrate that an active LGIA is in place and transferrable. For purposes of this RFP, in determining the LCOE of the proposed existing renewable energy resource, NV

Energy will include its resource integration costs. Transmission system losses and One Nevada transmission line available capacity may be considered for both feasibility and pricing evaluations.

The pro forma APA contemplates that Bidder will transfer the fee title interest in the relevant site to NV Energy. If Bidder intends for NV Energy to acquire site control through other means (e.g. through a lease agreement, license or otherwise), then this fact should be addressed in Bidder’s proposal and Bidder’s comments to the form of APA must reflect the intended method by which NV Energy will acquire and maintain site control. The APA, which is specifically for the transfer of fee title, will be subject to further revisions by NV Energy in order to accommodate the change in ownership or site control.

2.10 ESS System APA (Product 1C)

As noted above, NV Energy will consider qualifying proposals to enter into APAs for an existing stand-alone ESS in accordance with the requirements of Table 1 and in the form attached as Attachment D to this RFP. Bidder’s proposal must contain the required documentation listed in Attachment G and any proposed changes to the pro forma APA (Attachment D) in Microsoft Word format. Bidder’s proposal must also contain documentation of the completed process milestones, including demonstrating that a LGIA is in place or will be in place that allows for the proposed commercial operation date of the ESS. For evaluating Product 1C, in determining the levelized cost of energy storage (“LCOS”) of the proposed ESS system, NV Energy may consider transmission system losses and One Nevada transmission line available capacity for both feasibility and pricing evaluations.

Any proposal made for the sale of an existing energy storage resource must be made by Bidder with the understanding that the pro forma APA attached as Attachment D to this RFP will be the basis for any definitive agreement between Bidder and NV Energy, and the proposal pricing must reflect the terms and conditions as set forth in the pro forma APA.

2.11 Proposal for Build Transfer Agreement (Products 3A, 3B and 3C)

NV Energy will consider qualifying proposals to enter into build transfer agreements (“BTAs”) for new renewable energy resources, excluding geothermal (flash or binary), biomass and biogas, in accordance with the requirements of Table 1 and in the form attached as Attachment E to this RFP. Bidders should note the requirement in Table 1 that the applicable new renewable

energy resource must be constructed to NV Energy’s Engineering, Procurement and Construction (“EPC”) standards. The Facility shall be designed and configured such that it may be operated (dispatched) at an active power level that is lower than its instantaneous maximum power potential and be capable of delivering ancillary services up to the instantaneous maximum power potential of the facility.

Facilities shall have these capabilities:

- The facility must be capable at all times of being operated, via dynamic signal, at an active power level at or below the instantaneous maximum output of the resource.
- The facility must be capable of reserving a configurable amount of capacity which is continuously available based on operator inputs.
- The instantaneous maximum potential output must be capable of being calculated and provided dynamically and instantaneously to Company.
- The facility must have Automatic Voltage Regulation functionality.
- Bidder must provide operating characteristics of the facility that support automated signal operation, including:
 - Facility capable of operating dynamically on Automated Generation Control (AGC) signal every four seconds
 - Facility minimum active power output when on AGC
 - Facility instantaneous maximum output in real time when on AGC
 - Facility provided maximum and minimum ramp rates when on AGC
 - Facility capable of providing dynamic voltage support at continuously rated maximum output while operating at a Power Factor of 0.95 leading to 0.95 lagging when on AGC
 - Facility capable of providing dynamic frequency response of up to 5% droop when on AGC
 - Facility provides hours each of the above capabilities are available

Bidder’s proposal must contain the required documentation listed in Attachment G and any proposed changes to the pro forma BTA (Attachment E) in Microsoft Word format. For the purposes of this RFP, in determining the LCOE of the proposed new renewable energy resource, NV Energy will include its resource integration costs and the transmission network upgrade costs identified in the LGIA that are to be borne by NV Energy. These costs are to be included in Attachment G. Transmission system losses and One Nevada transmission line available capacity will be considered for both feasibility and pricing evaluations. All applicable security provisions are listed in the applicable pro forma agreement and associated attachments and exhibits.

Bidder's proposal must also contain documentation of the completed process milestones, including demonstrating that a LGIA is in place or will be in place that allows for the proposed commercial operation date. Transmission system losses and One Nevada transmission line available capacity may be considered for both feasibility and pricing evaluations.

The pro forma BTA contemplates that Bidder will transfer the fee title interest in the relevant site to NV Energy. If Bidder intends for NV Energy to acquire site control through other means (e.g. through a lease agreement, license or otherwise), then this fact should be addressed in Bidder's proposal and Bidder's comments to the form of BTA must reflect the intended method by which NV Energy will acquire and maintain site control. The BTA, which is specifically for the transfer of fee title, will be subject to further revisions by NV Energy in order to accommodate the change in ownership/site control.

Any proposal made for the sale of a new renewable energy resource and associated environmental and renewable energy attributes, with or without a ESS system, must be made by Bidder with the understanding that the pro forma BTA attached as Attachment E to this RFP will be the basis for any definitive agreement between Bidder and NV Energy, and the proposal pricing must reflect the terms and conditions set forth in the pro forma BTA.

2.12 No NV Energy Security; Approvals

PLEASE NOTE THAT NV ENERGY WILL NOT POST SECURITY TO SUPPORT ITS OBLIGATIONS UNDER ANY DEFINITIVE AGREEMENT. BIDDERS WHO WILL REQUIRE SECURITY FROM NV ENERGY SHOULD NOT SUBMIT A PROPOSAL UNDER THIS RFP.

NV Energy reserves the right to update, modify, or revise any or all of the terms and conditions contained in the pro forma agreements attached to this RFP. If a definitive agreement is reached with a Bidder, the agreement will be contingent on the approval of the PUCN and other governmental authorities, as required. NV Energy reserves the right to assign a definitive agreement, or assign or delegate any of its rights and obligations under a definitive agreement, in accordance with the assignment provisions contained in the applicable pro forma agreements attached to this RFP.

2.13 Performance and Reliability Standards

The performance and reliability standards for this RFP are incorporated or referenced in the pro forma agreements attached to this RFP. The Company is seeking performance and reliability standards that will, at a minimum, meet the compliance requirements set forth in NAC Sections 704.8777 through 704.8793, and provide the most value to NV Energy's customers by ensuring the resource is meeting load and is able to provide Nevada portfolio credits to meet its compliance requirements. Such performance and reliability standards are similar to those that NV Energy has required in prior renewable energy resource RFPs but have been updated to address changes in market circumstances and consistency in contract administration, all with the intent to ensure NV Energy's customers are afforded reliable and cost-effective energy resources.

3.0 SUBMITTAL PREPARATION INSTRUCTIONS

All proposals must comply with the requirements specified in this Section. Specifically, Bidders must organize their written proposals according to the format specified in this Section 3.0, and must provide all applicable information required in Sections 3.1.1 through 3.2.8. In addition, all proposals must be submitted in accordance with the requirements set forth in Section 2.5 of this RFP. *Please note, if you have submitted proposals in one of NV Energy's previous RFPs that some requirements and organization have changed.*

General Organization of the Proposal

All proposals must contain the following information and, to facilitate timely evaluation, must be organized as indicated below. The sections of the proposals must be as follows:

Part One

- 3.1.1. Cover Letter
- 3.1.2. Bidder Information

Part Two

- 3.2.1 Proposal Executive Summary
- 3.2.2 Technical Information
 - 3.2.2.1 Facility and Equipment Description
 - 3.2.2.2 Site and Route Characteristics
 - 3.2.2.3 Land Permitting/Acquisition and Demonstrated Site Control
 - 3.2.2.4 Environmental Permitting, Compliance and Authorization
 - 3.2.2.5 Construction and Operating Permits

- 3.2.2.6 Benefits of the Proposed Project to Nevada
- 3.2.3 Interconnection
- 3.2.4 Resource Supply
- 3.2.5 Assurance of Generating Equipment Supply
- 3.2.6 Project Execution Plan
 - 3.2.6.1 Project Schedule
 - 3.2.6.2 Safety Program
 - 3.2.6.3 Project Controls and Reporting Plan
 - 3.2.6.4 Quality Control Program
 - 3.2.6.5 Subcontractor Strategy
 - 3.2.6.6 Work Site Agreement Plan
 - 3.2.6.7 Staffing Plan
 - 3.2.6.8 Financing Plan
 - 3.2.6.9 Environmental Plan
 - 3.2.6.10 Facility Operation and Maintenance Plan
- 3.2.7 Contract Terms and Conditions
- 3.2.8 Other Information (may be provided in written proposal or as appendices)

All proposals should include complete responses to the parts set forth above in addition to the information provided in the relevant RFP attachments. Supporting documentation for these sections may be included separately as appendices by providing clear references to the sections concerned. Section titles should match those listed above. Attachment H (Bidder Proposal Compliance Checklist) is intended to aid Bidder in their compliance and is to be completed by inserting an “X” in column B for each completed item and returned with proposal.

If submitting a document as a separate file, the document name/reference must be stated in the written proposal (see file naming convention under Section 3.3). As an alternative, the document may be included as an attachment at the end of the written proposal, and should also be referenced within the body of the written proposal.

Supporting documentation in the form of an official document (e.g. permits, studies, applications, etc.) may be submitted as a comprehensive listing, in spreadsheet format, summarizing the pertinent aspects of the required documents. Please specify whether or not approvals have been obtained or applied for.

3.1 Part One of Proposal

3.1.1 Cover Letter

The cover letter must include all signatures necessary to approve and submit Bidder's proposal by one or more representatives¹¹ having the authority to contractually commit Bidder to Bidder's offer(s) provided in the proposal. Additionally, the cover letter must be addressed to NV Energy and include the following declaration:

“**[Insert legal name of Bidder]** (the “Bidder”) acknowledges receipt of NV Energy's 2020 Fall Renewable Energy Request for Proposals on or about January 21, 2020. Bidder makes the following representations to NV Energy:

1. All of the statements and representations made in this proposal are true to the best of Bidder's knowledge and belief;
2. Bidder possesses a legally binding agreement(s) or option(s) to possess all necessary land rights for sufficient site control to undertake development of the project as set forth in the proposal, including ingress and egress to and from the site;
3. Bidder possesses or will possess all necessary water rights for construction and ongoing maintenance of the project through the term of the agreement;
4. Bidder has obtained, or can demonstrate how it will obtain, all necessary authorizations and approvals that will enable Bidder to commit to the terms provided in this proposal;
5. This proposal pertains to a renewable energy system, including environmental and renewable energy attributes, from a renewable energy system. The renewable energy system will meet the requirements of NRS § 704.7315, § 704.7811 and § 704.7815; and NAC § 704.8831 to 704.8893; and the generating facility is or will be qualified as a renewable energy system in accordance with

¹¹ If the proposal is being bid under a partnership, the partnership must be fully established, including a legally binding agreement (not a letter of intent), prior to submission of a proposal under this RFP. Each partner shall be bound to comply with the terms of this RFP and the proposal. The signature of each partner must be included on the cover letter, along with their contact information (i.e. company name, phone number, email address, etc.). The proposal must include evidence documenting the legal and binding partnership with an effective period that extends well beyond the expected contract execution date stated in Table 1 (RFP Schedule), otherwise the proposal will not be accepted.

- NRS §704.7801 to 7828; and the associated regulations promulgated by the PUCN;
6. Bidder has read the requirements, obligations and disclaimers of this RFP and understands Bidder's obligations and NV Energy's rights.
 - 7 Bidder and its legal counsel have reviewed the pro forma agreement(s), and Bidder's provided mark-up(s) of the applicable pro forma agreement(s) reflect all of the now known issues that Bidder may have, or revisions that Bidder intends to request, with respect to the applicable pro forma agreement(s);
 8. Bid pricing is based on the terms of the pro forma prior to the markups; and
 9. This proposal is a firm and binding offer, for a period of at least 220 days from [insert date of letter/bid submittal].”

3.1.2 Bidder Information

In this Section Bidder should provide the following information:

- Organization Structure: Profile of Bidder's organization and its ownership structure (including direct ownership and ultimate parent company, which can be in the form of a diagram);
- Equivalent Development: Description (including total nameplate, gross and net capacities) of generating facilities (including associated substation, transmission and distribution lines, water/gas lines, and telecommunication systems, as applicable) and ESS systems, if applicable, of the same technology and equivalent or larger capacity proposed in the proposal which were successfully and fully developed (from start to finish), including land/property acquisition, permitting, construction, and placement into commercial operation by Bidder; not to include projects acquired after start of development;
- Equivalent Ownership/Operation: Description (including nameplate, gross and net capacities) of generating facilities (including associated substation, transmission and distribution lines, water/gas lines, and telecommunication systems, as applicable) and ESS systems, if applicable, of the same technology and equivalent or larger capacity proposed in the proposal which are currently in service and owned or operated by Bidder (and not otherwise set forth in response to the above request);

- Similar Development: Description (including total nameplate, gross and net capacities) of generating facilities (including associated substation, transmission and distribution lines, water lines, gas lines, and telecommunication systems, as applicable) and ESS systems, if applicable, of any technology and equivalent or larger capacity, that have been successfully and fully developed (from start to finish), including land/property acquisition, permitting, construction, and placement into commercial operation by Bidder; not to include projects acquired after start of development;
- Shared Ownership or Operation: Description (including nameplate, gross and net capacities) of generating facilities (including associated substation, transmission and distribution lines, water/gas lines, and telecommunication systems, as applicable) and ESS systems, if applicable, of any technology and equivalent or larger capacity, that are owned or operated by Bidder and currently in service (and not otherwise set forth in response to the above request);
- Other Projects: Description (including nameplate, gross and net capacities) of generating facilities (including associated substation, transmission and distribution lines, water/gas lines, and telecommunication systems, as applicable) and ESS systems, if applicable, of any other similar projects not otherwise set forth in response to the above requests;
- Nevada Development Experience: Bidder's pertinent experience developing (i.e. siting, routing, acquiring land rights, permitting, transmission, telecommunications, and other associated project components) similar or comparable types of projects, within the state of Nevada;
- Federal and Tribal Lands Experience: Bidder's pertinent experience in developing (i.e. siting, routing, acquiring land rights, permitting, transmission, telecommunications and other associated project components) similar or comparable types of projects, on federal or tribal lands (i.e. Bureau of Land Management or Bureau of Indian Affairs, respectively) within Nevada and/or other states within the United States;
- Licensing: Bidder's Nevada contractor's license information; and
- Litigation: Any current litigation that Bidder, or any of its subsidiaries (including any off-balance sheet entities in which Bidder has an interest) is involved in regarding an energy generating facility or an energy supply contract.

Note: Bidder contact and corporate information is to be provided in Attachment G under the “Corporate Information” tab.

As evidence of financial capability to carry out its obligations explicitly articulated or implied in the proposal, the following information must also be included in this Section¹² of the proposal for Bidder’s company, any parent company and any partners¹³ involved with the generating facility or ESS system, and all appurtenant facilities, proposed in the proposal:

- Current bond ratings, if any;
- Current rating agency ratings or reviews, if any;
- Audited financial statements and footnotes, including cash flow statements, from the last three (3) years. If Bidder does not have audited financials, Bidder must provide equivalent financials or the audited financials of the nearest level parent company;
- If financing has not been secured for the proposed project, provide information demonstrating that project financing can be secured, including references to lenders from other project financings who have a potential interest in the proposed project;
- If a guarantee of support is to be provided by an affiliate of the Bidder that affiliate must provide the above financial information and a guarantee that is enforceable in the United States;
- Provide information on the number of projects that Bidder has received financing on within the last three years for: 1) similar technology; and 2) similar or larger capacity;
- Describe any bankruptcy proceedings that Bidder, its direct affiliates or the proposed project is involved in, including current status and expected outcome; and
- Other financial information that would be pertinent to NV Energy’s evaluation of Bidder’s financial capability.

NV Energy’s Credit Department will analyze the required financial criteria to determine, in its sole discretion, Bidder’s financial capability to successfully implement its proposal, and may require the provision of credit support in connection with the definitive agreements.

¹² See related Section 3.2.6.8, Financing Plan, under Project Execution Plan

¹³ See footnote under Section 3.1.1.

3.2 Part Two of Proposal

3.2.1 Proposal Executive Summary

The Executive Summary should highlight the content of the proposal and features of the offer broken down by resource and site. Each resource and site description must include the commercial operation date, the amount of energy being offered, the type of energy being offered (e.g., wind, solar, geothermal, etc.), a general description of the pricing proposal, the status of interconnection, a summary description of the transmission and telecommunication interconnection with location and route for the project to connect to the NV Energy transmission system, a summary description of project water supply agreement(s) and plans for water delivery/use, a summary description of land and environmental permitting including any major land constraints and/or natural resource concerns, description of current land rights, proposed land rights to be acquired and any other pertinent land right information whether federal, state, local or private and whether the overall project facilities (e.g. generation, transmission/distribution, access roads, water/gas pipelines, telecommunication systems, etc.) are currently operational, in construction, or in development. In addition, this Section should identify any material government incentives that are being sought in connection with the proposal.

3.2.2 Technical Information

Bidders must provide technical information regarding the proposal as described below. Attachment G, provided as a separate Microsoft Excel file, must be completed in its entirety and in accordance with the corresponding instructions in order for proposal to be considered in conformance. A separate Attachment G must be submitted for each bid/pricing option. Attachment G is used for modeling and scoring. Do not modify the file other than to provide responses in the yellow input cells. Complete the file in full and avoid inserting comments where a value is expected, particularly numeric values. Please note that alternative offers within the written proposal, without a corresponding Attachment G, will not be considered for initial shortlisting. Any discrepancies between Attachment G and proposal documents, Attachment G will rule. If the project is bid using photovoltaic (“PV”) technology, the plant capacity and pricing should reflect the facility’s AC MW rating.

Responses under the Non-Price Input worksheet of Attachment G are to be concise with details provided in Part Two of the proposal. Do not simply refer to the proposal document, provide a summary response to each question. Column E of the worksheet should include proposal page/section references where the detailed information is located, as applicable. It is to provide references to the detailed information/clarifications provided under Part Two of the proposal, and is not acceptable, on its own, as a response to a question. Responses under the Non-Price Input worksheet will be scored.

Use caution if copying Attachment G for multiple bids (not recommended), that Product, Type, Bid #, project name, capacity, MW, price, etc. are correct for each individual bid under the Price Input, 8760 Prod. Profile, Price Input-ESS, Financial Inputs, and Economic Benefits worksheets. Ensure that there are no data links to other files before uploading to BHE JAGGAER.

Attachment G, as provided within this protocol document, contains an outline of the Microsoft Excel file that is to be completed for each bid and pricing option.

In addition, Bidder must provide the following information describing the generating facility and/or ESS system, as well as all appurtenant facilities (as further described in Sections 3.2.2.1 through 3.2.2.5):

- Facility and Equipment Description
- Site and Route Characteristics
- Land Permitting/Acquisition and Demonstrated Site Control
- Environmental Permitting and Compliance Authorization
- Construction and Operating Permits
- Benefits of the proposed project and/or ESS Systems to Nevada

3.2.2.1 Facility and Equipment Description

Bidder must include a description of the generating facility and/or ESS systems as well as all appurtenant facilities forming the basis of the proposal to NV Energy. All facilities should be included in the description (e.g. gen-tie line(s), roads, affected NV Energy substation(s), water lines and source, gas lines, etc.), including identifying and describing any and all facilities and/or equipment shared with a third party or under a separate agreement. This Section, along with Attachment G, should also include information related to the type of plant, configuration, general

layout diagrams, preliminary site plan showing site boundaries and plant layout, single-line diagram including metering scheme (see Attachment O for examples), resource type (e.g. wind, solar, geothermal, etc.), nameplate capacity rating (MW AC), net plant capacity (MW AC), annual net output (MWh), net output for each hour of the year (MWh), projected capacity factor, proposed in-service date, and the current or contemplated major equipment providers. See Section 3.2.5 regarding major equipment providers and the approved vendors list (Attachment K). In addition, provide information, including technical specifications, for the major equipment that will be used in this project. To demonstrate commercial use at a similarly sized, and environmentally comparable site, explain how many similar projects the equipment has been used in, or identify if it is a first-of-its-kind scale. Demonstrate or explain quality of materials that will be used in relation to competitor materials, if applicable. If available, provide a third party, independent engineer's report that verifies the performance of the proposed equipment.

If the proposal is based on an existing generating facility, Bidder must provide historical data (a) for the last three (3) years, or (b) if the age of the generating facility is less than three (3) years, from when the generating facility was built. Existing generating facility information must also include the historical production schedule, net output rating (MW AC), capacity factor, equivalent availability, forced outage rate, scheduled outage rate, deratings, and the forecasted five (5) year scheduled maintenance cycle and production schedule. Any known flexibility as to the timing of the maintenance schedule must also be described. If the plant has any Trench bushings installed on generator step-up ("GSU") transformers, explain how many, what voltage, what vintage and where they were manufactured. Bidder must also provide a general (non-confidential) description of any existing or proposed energy and capacity arrangements involving the generating facility and how they relate to this proposal.

If the proposal for sale of energy is from a new facility that is yet to be built, Bidder must describe any feasibility studies performed for the proposed facility as well as all appurtenant facilities. Bidder must also describe the level of engineering completed for the facility as well as all appurtenant facilities and the plan for equipment procurement and construction. Bidder should also identify any contractors that have been engaged to provide any of these services. Bidder should also describe any innovative technical features of the facility as well as all appurtenant facilities, incorporating new energy technologies. Trench bushings are not permitted on GSU

transformers. If innovative technical features are included, Bidder must describe any previous experience with implementation of such technical features and the level of risk involved in this application. A production profile for the generating facility must be provided showing the energy deliveries in average energy production by month and time of day. The data and evaluations provided must support the proposed level of generation and the projected capacity factor.

For ESS systems bids, Bidder must provide a description of the plant communications and control plan. The plan shall include a description and diagrams (as applicable) that demonstrate how Bidder will provide:

- ESS systems data, including state of charge, power charge/discharge status, and asset health indicators (temperature, HVAC alerts, emergency status, etc.)
- ESS system control, including limitation of charging only from renewable energy production, charge/discharge scheduling, and station service load

All information provided in this Section must be consistent with the information provided in Attachment G, which includes information required for the evaluation of the proposal as further described in Section 5.0 of this RFP.

3.2.2.2 Site and Route Characteristics

As applicable, Bidder must:

(a) Provide a legal description, including, County, Section, Township & Ranges and metes and bounds legal description with exhibit, of the facility as well as all appurtenant facilities and, both a street map and the appropriate section of a USGS (or equivalent) map showing the location and boundary/route of the facility and/or ESS systems as well as all appurtenant facilities. The maps should show all land parcels, with parcels owned, leased or optioned by Bidder clearly marked.

(b) Provide an aerial photo and Google Earth® file of the project site showing project boundary(s), linear facility route(s), and a layout of the proposed facilities.

(c) Provide the County Assessor's parcel number, site address, and site coordinates for all project facilities.

(d) Provide an ALTA/ACSM survey of the project site if such survey has been conducted. This survey will be required if the proposal is selected under the final shortlisting, and in accordance with the applicable pro forma agreement.

3.2.2.3 Land Permitting/Acquisition and Demonstrated Site Control

As applicable, Bidder must:

- (a) Provide a list of all land parcels for the project, including current ownership.
- (b) Provide a description of the legally binding lease or ownership arrangement¹⁴ for each parcel, along with all copies, including amendments, of fully executed leases, deeds, options, purchase agreements, preliminary title reports, easements, other land rights and other documentation for private, local municipalities and state owned lands, as well as any other non-federal owned lands (e.g. Union Pacific Railroad), that are in place or contemplated for the site and all linear appurtenances (e.g., gen-tie lines, microwave facilities, access roads, substation expansions, etc.), the number of acres at the site and of all linear appurtenances, site access roads and, as applicable, water supply agreement or the plan for securing sufficient water, the waste disposal plan, fuel supply (as applicable), associated water/fuel transmission plans, or other infrastructure additions required outside of the site boundaries for the proposed project to be implemented.
- (c) Specify the quantity of water required for construction and operation of the facility for the full life of the project. Provide status of necessary documents or permits required for securing sufficient water rights or other water supply, including date delivery will commence, name of water purveyor, acre-feet annually, pump rate, limitations, location of source and proximity to project, any supplemental sources, and permitting or licensing status. As applicable, explain if water right application is in permitted or certificated status. Provide copies of any permits, and agreements or letters of intent with a third-party to secure sufficient water supply.

¹⁴ A non-binding letter of intent to reach an agreement or an agreement that is not fully executed is unacceptable. A legally binding option agreement is acceptable.

(d) Provide all documentation of exclusive or non-exclusive site control¹⁵ or a description of the current status of efforts to secure such site control for all Federal Agency managed land regardless of how the land is actually held (e.g. in Trust for the Bureau of Indian Affairs, withdrawn for branch of military, Bureau of Land Management). For all federal lands, provide SF299 application packages, or agency specific application, including but not limited to, all exhibits, attachments and the Plan of Development. Provide all federal right of way offers/grants and/or option agreements, Limited or Full Notices to Proceed, or agency specific land right, etc. if already issued by the respective agencies. Provide a detailed explanation that verifies all land acquisition efforts such as, but not limited to, fees paid, option agreements, executed Tribal consent, executed Tribal Term Sheet, Bureau of Indian Affairs (BIA) consent, Military Branch approval, expected dates for approvals, executed site option(s) with ongoing option payments, unilateral right to strike on site option(s) at agreed upon price(s) over the term of the option agreement(s), any future site procurement costs, etc.).

(e) If 100% site control has already been attained, provide a detailed explanation that identifies all environmental mitigation requirements that will be required to be implemented along with estimated costs and scheduling.

(f) List and provide a description of all Land Use Permits, including but not limited to Special Use Permit from local governmental agency, and provide copies if available.

(g) Provide a detailed list of all applicable state, local and federal land permits and authorizations anticipated for securing land rights for the facility as well as all appurtenant facilities that authorize the construction and operation of all facilities. Provide a detailed critical path schedule containing clear and concise task descriptions and anticipated timelines for securing those permits and approvals.

(h) Identify important milestones and decision points in the schedule along with an explanation of how land permitting activities will be coordinated within the overall construction and development schedule.

¹⁵ A Tribal letter of intent to reach an agreement not addressed to Bidder or not accompanied by an executed Term Sheet or an agreement that is not fully executed is unacceptable. A legally binding option agreement is acceptable, provided that it includes all the terms of the lease agreement.

(i) Identify and fully describe the arrangements of any and all facilities and/or equipment shared with a third party or under a separate agreement, even if the separate agreement is with NV Energy. Include any impacts to NV Energy due to such shared facilities/equipment and plans to alleviate potential negative impacts.

3.2.2.4 Environmental Permitting, Compliance and Authorization

Bidder must also:

(a) List and provide a description of all local, state and federal environmental requirements, authorizations, permits, etc., anticipated to be required in order to support the acquisition of land rights, as well as to construct and operate the generating facility and/or ESS systems as well as all appurtenant facilities in accordance with all applicable environmental laws and regulations. Provide a detailed critical path schedule containing clear and concise task descriptions and anticipated timelines for securing those permits and approvals along with all associated environmental compliance tasks and activities required by any regulatory agency(s).¹⁶

(b) Describe all coordination efforts/actions already taken, or anticipated to be taken, with local, state, and federal agencies with respect to environmental permitting and regulatory compliance with a description of current status of each effort/action.

(c) Provide any evidence that an environmental assessment, an environmental impact statement or an environmental impact report is being completed or has been completed with regard to the renewable energy system, or any evidence that a contract has been executed with an environmental contractor who will prepare such an assessment, statement or report within the 3-year period immediately preceding the date on which the renewable energy system is projected to begin commercial operation.

(d) Provide copies of all environmental permit applications with associated attachments, any environmental analysis and review documents pursuant to the National Environmental Policy Act, Endangered Species Act, National Historic Preservation Act, Clean Water Act, Clean Air Act, etc., documents of any environmental surveys conducted, land/environmental constraint studies, environmental site assessments, hazardous material, waste

¹⁶ See related Section 3.2.6.9, Environmental Plan, under Project Execution Plan

material reports or other information associated with the land(s) acquisition and land use to support the proposed generating facility and/or ESS systems as well as all appurtenant facilities.

(e) Describe any existing environmental issues of concern associated with the generating facility and ESS systems as well as all appurtenant facilities, such as site contamination, presence of waste disposal area, state or federally protected plant and wildlife species or habitats and species of concern present or potentially present, National Conservation Lands, wetlands, and any other known or potential environmental issues, with an explanation of how Bidder will address any such issues so as to maintain the ability to meet the anticipated commercial operation date and other long-term obligations of the agreement.

(f) Include any current Phase I or Phase II environmental site assessment reports/action conducted by or available to Bidder.

(g) Describe whether or not the project would potentially require any air permits, and if so, provide any air quality modeling results, and estimated air emission rates identified or expected to be included in an air permit process.

(h) Describe the land uses adjacent to and in proximity of the generating facility and/or ESS systems as well as all appurtenant facilities. Describe current or planned efforts to build local community support.

(i) Provide copies of environmental permits already successfully secured, including their associated applications and supporting documents, studies and reports.

(j) Identify important milestones, all key environmental tasks and activities, and decision points in the schedule along with an explanation of how environmental permitting and regulatory compliance activities will be coordinated within the overall development schedule, including construction and operation and maintenance.

3.2.2.5 Construction and Operating Permits

Bidder shall provide a list of permits required for construction, operation and occupancy of the proposed project. Bidder is responsible for obtaining all permits. Additionally, Bidder shall:

(a) Describe all local, state and federal construction requirements, authorizations, permits, (e.g. grading, stormwater, fencing, building, dust control, occupancy, etc.) anticipated in

order to construct and operate the entire project in accordance with all applicable laws and regulations.

(b) Describe all coordination efforts and actions already taken, or anticipated to be taken, with local, state, and federal agencies with respect to acquiring the necessary construction and operations related permits.

(c) Describe any existing on-site construction issues of concern that may impact the ability to meet the anticipated commercial operation date. Include risk mitigation efforts planned to maintain the commercial operation date.

(d) Provide copies of any construction and operating permits already secured, including their associated applications and supporting documents, studies and reports.

(e) Provide a detailed critical path schedule containing clear and concise task descriptions and anticipated timelines for securing all applicable state, local and federal construction and operating permits.

(f) For wind projects, include airspace and radar clearance, Federal Aviation Administration (“FAA”) and Federal Communication Commission (“FCC”) permit status if applicable.

3.2.2.6 Benefits of the Proposed Project to Nevada

Bidder must describe any other special expected environmental, social, or economic benefits of the proposed project, including value attributes (e.g. availability, dispatchability, scheduling, fuel diversity, hedging, ancillary services, etc.). Bidder must describe how the project will provide the creation of new jobs in the state of Nevada. In addition, Bidder must also complete the applicable economic benefits spreadsheet in Attachment G. Instructions are provided in the “Economic Benefit Input” tab. All inputs should only include *direct* costs and job data in Nevada.

3.2.3 Interconnection

Bidders are expected to have an LGIA or a completed Facilities Study submitted with their proposal. Bidder must provide the status of such interconnection documents. Bidder shall demonstrate that the resource can effectively be integrated through the transmission path or as a

network resource to NV Energy, and explain any known transmission constraints. Bidder shall specify whether any ancillary services have been confirmed. Bidder must provide copies of the completed Facilities Study or the LGIA in final or draft form. Bidder will also identify the anticipated interconnection point and in-service date for the proposed facility. The in-service date must be as specified by the transmission provider and well in advance of the required commercial operation date in order to allow for testing. For proposals where an LGIA has been executed, Bidder will provide documentation supporting any completed milestones.

All proposals that will require a new electrical interconnection or an upgrade to an existing electrical interconnection must include all costs to interconnect to the transmission provider's system, as specified in the LGIA or Facilities Study. In addition, bidder shall provide a diagram of the interconnection facilities provided in the LGIA or the most recent Facilities Study on the project, as completed by the transmission provider. The interconnection costs for network upgrades will be included in the LCOE calculation. Bidders will describe interconnection costs in their proposals by disclosing that portion of costs associated with network upgrades and that portion that is facility-specific. Bidders are reminded that the cost responsibility for all transmission facilities will be pursuant to the provisions of the OATT. The Interconnection Customer is responsible for all of the Transmission Provider's Interconnection Facilities ("TPIF") costs. The Transmission Provider is responsible for the costs associated with Network Upgrades ("NU") pursuant to the OATT; however, such costs will be securitized by the Interconnection Customer as provided under the provisions of the OATT. Interconnection Customer's Interconnection Facilities ("ICIF") are the sole responsibility of the Interconnection Customer.

If the existing renewable energy project LGIA does not already include the proposed ESS systems, the LGIA will need to be amended and restated to incorporate the ESS systems. The Interconnection Customer specified in the LGIA will need to submit an evaluation for a material modification along with updated plant specifications and generator model data to the Transmission Provider in accordance with the applicable Open Access Transmission Tariff requirements.

Bidder must provide a copy of its executed Voluntary Consent in the form provided in Attachment B of this RFP. The original must be submitted directly to the transmission provider, separate from the RFP proposal, on or before submission of the proposal.

3.2.4 Resource Supply

Bidder must provide sufficient information with respect to resource supply to provide assurance to NV Energy that the facility will be able to meet its projected production estimates for the full term of the PPA or, if applicable, the expected useful life of the generating facility and provide the means and specifications to meet the dispatchability requirements. Provide any third-party resource assessment reports supporting the expected capacity factor. In addition, identify proposed manufacturers and model numbers for major equipment. In particular, the following information is requested for the different technologies:

Geothermal

- Provide a summary of all collected geothermal data for the proposed generating facility site.
- Characterize the geothermal resource quality, quantity and projected production levels.
- Provide a graph or table that illustrates the annual and monthly projection of geothermal resources.
- Describe any other existing geothermal facilities in the resource area and characterize their production and their anticipated impact, if any, on the generating facility.
- Provide a minimum of one production well and one injection well flow results to support the viability and capacity of geothermal resource. For results in excess of three (3) years, summarize the results for all years and provide the detail for the past three (3) years of production well flow tests.

Solar

- Describe the sources of insolation data, either onsite, satellite, or a nearby station. If using a nearby station, state the exact distance from that station.
- Provide source and number of years of solar data used to support the capacity factor.
- Provide a third-party PVSyst report or similar assessment report based on credible solar radiation meteorological data.
- Specific resource and technology, including a requirement that all bids include panels manufactured by a Tier 1 solar panel manufacturer, and inverters from a vendor on the Approved Vendors List (Attachment K).

Wind

- Provide a summary of all collected wind data for the generating facility site.
- Indicate where the data was collected and its proximity to the generating facility site.

- Provide one (1) year of applicable wind resource data utilizing at least two anemometers for any wind project to support capacity factors and a third-party wind resource assessment report based on meteorological tower data.
- Compare the long-term wind speeds in the area to the collected resource data at the generating facility site.
- Confirmation of wind turbine availability and size.

Biomass

- Describe the biomass fuel makeup and its source.
- Provide third-party resource assessment reports of available biomass fuel for the generating facility and its proximity to the generating facility. Such resource assessments should include a discussion of long-term fuel price risk and availability risk issues.
- Identify competing resource end-uses.
- Provide a plan for obtaining the biomass fuel, including a transportation plan.
- Identify any contracts or option agreements to acquire and transport the biomass fuel.
- Provide an agreement or option agreement with a biomass fuel source for a period of ten (10) years or greater.

Biogas

- Provide third-party resource assessment reports of available biogas fuel for the generating facility and its proximity to the generating facility. Such assessment reports should include at a minimum: history of landfill, total volume permitted, volume filled, estimated closure date, organic fraction of the municipal solid waste, moisture levels, temperatures and pH of the waste, future waste receipt, increase or decrease and average rainfall in the area.

ESS

- ESS systems degradation, round trip efficiency, controls, location, life, cycles, load duration, descriptions of all facilities and equipment shared with the associated renewable generation facility, and the other applicable information listed in Attachment G. Include a discussion of ESS chemistry, whether the system is alternating current (“AC”) coupled or direct current (“DC”) coupled and how degradation will be managed (e.g. overbuild, augmentation, etc.).

3.2.5 Assurance of Generating Equipment Supply

To demonstrate ability to deliver on time, Bidder must list and demonstrate that it has access to, or has completed sourcing of, the necessary major equipment, consistent with the Approved Vendors List provided in Attachment K of this RFP, to complete the design, engineering and construction of the facility contemplated in the proposal to meet the stated commercial operation date.¹⁷ Provide details of all equipment including supplier detail, make and model and any form of supply, warranty and performance commitment from suppliers. If Bidder has a preferred equipment provider that is not included in Attachment K, please identify the vendor and their experience within the United States for projects of similar technology and size, detail Bidder's reasoning for the preference, and specify any direct experience Bidder has had with the vendor. If a contract is in place for any equipment, please identify the contracted party. Provide a mark-up of Attachment K if recommending new vendors. Attachment K will become part of the applicable pro forma agreement.

3.2.6 Project Execution Plan

Bidder will provide a summary-level, site-specific project execution plan. The project execution plan will be referenced and become part of the pro forma agreement. Key elements of the execution plan are:

3.2.6.1 Project Schedule

Bidder must provide a detailed project schedule that includes the anticipated period to permit and complete the project in order to achieve commercial operation, referenced in months, following receipt of all regulatory approvals, including PUCN approvals (i.e., IRP and UEPA). This time period must allow for environmental and land right acquisition and permitting, environmental studies, mitigation and treatment, transmission construction, financing, site development, construction permitting, construction, testing, and any other development and construction requirements. Bidder must provide a milestone schedule for the proposed project, inclusive of the major development milestones listed below (as applicable):

- Major Equipment Ordered;

¹⁷ See related Section 3.2.6.4 , Quality Control Program, under Project Execution Plan

- Project Interconnection to Transmission System;
- All Permits Obtained for land, environmental and construction;
- All land rights acquired;
- Construction Financing Obtained;
- Construction Start;
- Environmental Compliance/Mitigation;
- Operation Date (first energy to grid); and
- Commercial Operation Date.

These milestones should be noted in number of months following receipt of all regulatory approvals, including PUCN approvals (i.e., IRP and UEPA).

Bidder also shall describe any measures to be taken to ensure the proposed schedule will be met.

Note that Bidder will be required to post security following execution of a definitive agreement and prior to the submittal of the definitive agreement for PUCN approval (i.e., IRP).

3.2.6.2 Safety Program

The development and implementation of a good safety program at the site is of paramount importance to NV Energy. Safety is a core principle of NV Energy and is a priority in every aspect of our business. The same level of safety diligence is expected from contracted parties. Bidder's safety program must comply with or exceed NV Energy's safety requirements, as outlined in Attachment J to this RFP. Any exceptions or comments must be noted in Bidder's proposal. As part of its proposal, Bidder must submit its corporate safety incident report for the preceding five (5) years.

3.2.6.3 Project Controls and Reporting Plan

Bidder will submit their Project Controls and Reporting Plan, including a summary (Level II) construction schedule displaying major activities, durations and proposed sequencing which demonstrates Bidder's proposal to achieve substantial completion prior to the operation date as listed in its proposed Project Schedule as provided under Section 3.2.6.1.

3.2.6.4 Quality Control Program

Bidder will provide an outline of its Quality Control Program in line with its proposal, including, in accordance with the Approved Vendors List (Attachment K), the plan for procurement of equipment.

3.2.6.5 Subcontractor Strategy

Bidder will provide detailed information as to a proposed execution plan for its proposed project, including the name and experience of anticipated major subcontractors. It is the expectation that Bidder (or an affiliate thereof) would remain primarily responsible for the obligations of Bidder regardless of whether the obligations are performed by Bidder or a subcontractor.

3.2.6.6 Work Site Agreement Plan

A pro forma work site agreement (“WSA”) is attached as Attachment N to this RFP. This form may be modified based on the applicable unions and their associated master agreements. The form of WSA, as modified, or an executed WSA, is to be inserted in the applicable exhibit of the agreement being proposed. Bidders who take exception to the terms of the WSA agreement must provide a mark-up of the agreement, including Bidder’s proposed language. In addition, a statement of acceptance of the agreement as written, or explanation of each exception must be provided within the proposal. Please note that the WSA agreement is between Bidder and the union(s), not Bidder’s contractor.

Bidders that advance to the initial shortlist shall commence discussions with the unions immediately following notice of shortlisting. Bidders that advance to the final shortlist are required to provide weekly updates on the status of their WSA negotiations with the union(s). Bidders must provide an executed WSA, with Nevada union(s), prior to or at the time of execution of the RFP agreement. Bidder must be a signatory on the WSA. If Bidder elects to contract with an EPC, the EPC will be required to comply with the terms of the WSA.

3.2.6.7 Staffing Plan

Bidder shall provide a good faith estimate of the following (*values for Nevada only*):

- Number of *direct* jobs during construction (full-time equivalent) average and at peak construction and average salary of construction staff.
- Number of *direct* jobs during operation and maintenance (full-time equivalent).
- Average annual Salary of such jobs during operation and maintenance.
- Total *direct* payroll expenditure over the term of the agreement (e.g. 25 years).

The above estimates should match the values provided in Attachment G under the Economic Benefits Input worksheet, as applicable (i.e. Solar PV, Wind, Geothermal, etc.). If a contract is executed, these values will be stated in the regulatory filing for PUCN approval.

3.2.6.8 Financing Plan

Bidder should provide a detailed description of the financing plan for the proposed project (government, private, self-funded, balance sheet, power purchase agreement, etc.) and general description of status. If financing has been secured for the proposed project, provide commitment letter from financier.

3.2.6.9 Environmental Plan

Provide a detailed description of how Bidder will develop, permit, construct, operate and maintain the generating facility and/or ESS systems as well as all appurtenant facilities that includes the known and anticipated environmental permits, environmental activities associated with any land and permitting efforts, and known and anticipated mitigation measures required for pre-construction activities, construction activities and post-construction activities.

3.2.6.10 Facility Operation and Maintenance Plan

Bidder must provide a description of the expected operation and maintenance (“O&M”) plan for the facility as well as all appurtenant facilities. This information should include the following:

- Whether Bidder or affiliate will operate and manage the facility as well as all appurtenant facilities or will contract for O&M services. If Bidder will contract for O&M services, explain the current status of selecting an O&M contractor.
- Completed integrated solar and storage O&M term sheets and pricing for facility as well as all appurtenant facilities.

- A brief description of the basic philosophy for performing O&M including a discussion of contracting for outside services.
- Planned maintenance outage schedules.
- Plan for replacement of major equipment during the term of the contract.
- Plan for any land rights issues or environmental concerns including any post-construction environmental compliance monitoring, studies and reports as well as ongoing environmental compliance requirements during operations and maintenance.

3.2.7 Contract Terms and Conditions

Bidder's proposals will be scored based on the number and extent of risk shifting which results from Bidder proposed revisions to the applicable pro forma agreement(s) and related exhibits included as attachments to this RFP. Bidders who take exception to the terms of the pro forma agreements must provide a comprehensive mark-up of the applicable agreements, including Bidder's proposed language modifications (not just comments). Mark-ups should be provided in Microsoft Word format. In addition, a statement of acceptance of the agreement as written, or explanation of each exception must be provided within the proposal. **Proposals submitted without a comprehensive mark-up or in the alternative acceptance of the pro forma, may be disqualified.** Allowances will be made for mark-ups to ESS systems provisions. Attachment K and Attachment N of this RFP bid protocol document are to be inserted in the applicable exhibits of the agreement. **Bidder is required to have an officer of its company certify that the applicable pro forma agreements have been thoroughly vetted, including review by Bidder's legal counsel, and that the pro forma agreements either are accepted or the mark-ups provided by Bidder are substantially complete. See item 7 of cover letter under Section 3.1.1 of this RFP bid protocol document.**

3.2.8 Other Information

Bidder should provide any additional information that will assist NV Energy in its evaluation of the proposal. The proposal should indicate whether or not other information has been provided, and specify or list (if appendage) the other information.

3.3 Bid Numbering and File Naming Convention

Bid numbers will be self-assigned by Bidder in accordance with the directives below. There is no limit to the number of proposals that may be submitted. See [Section 2.6](#) regarding Bid Fees.

Bid numbers shall be a whole number followed by one decimal place, beginning with the number 1.0. Each subsequent proposal will have a separate sequential bid number (i.e. 2.0, 3.0, etc.). The decimal place will be used to indicate pricing options,¹⁸ necessary for [Attachment G](#). The initial proposal/pricing option will be identified as 1.0 and the second pricing option, for the same proposal, would be 1.1.¹⁹ Bidder's next proposal, if any, would be 2.0 with 2.1 as the second pricing option, and any additional pricing options would be 2.2 and 2.3, as applicable.

File names should be kept short by using abbreviations wherever possible. All required documents must use the following naming convention:

➤ [Abbreviated Bidder name]_[Bid number]_[Abbreviated_File_Descriptor]

For appendices, include appendix number and RFP section reference in the abbreviated file descriptor (i.e. XYZ_1.0_Part_2_Appx_1_3.2.2.1_SLD). See [Attachment P](#) (Proposal Zip File Structure) for further file naming examples.

All files related to a single bid must be compressed together and uploaded into BHE JAGGAER as a single .zip file named [Bidder name abbreviated]_[Bid number].zip (example: "NVE_1.0.zip"). Folders and subfolders for specific document types should be included in the .zip file following the directory structure/organization and folder naming convention provided in [Attachment P](#) (Proposal Zip File Structure). Documents provided in this RFP that have been modified by Bidder and any additional files provided by Bidder must apply the naming convention specified above before being compressed into the .zip file. *Please note, the .zip file associated with a bid may be quite large and take some time to upload, so please plan adequate time to upload each bid's .zip file into BHE JAGGAER hours in advance of the bid submission deadline.*

¹⁸ See Section 2.6 regarding qualified pricing options, and requirement for separate [Attachment G](#) for each option.

¹⁹ For PPA bids where a 15 year and 25 year add the term length at the end of the file name (e.g. 15, 25).

4.0 STANDARDS OF CONDUCT

Each Bidder responding to this RFP must conduct its communications, operations and other actions in compliance with FERC's Standards of Conduct for Transmission Providers. Any necessary interconnection to, or transmission service on, NV Energy's transmission system contemplated in a Bidder's proposal will not be considered an arrangement with NV Energy's merchant function, which is sponsoring this RFP. Such arrangements for interconnection and transmission service will be with NV Energy's functionally separate transmission function, and therefore, absolutely no communication by a Bidder to NV Energy's transmission function can be made through the submission of a proposal in this RFP. **Any Bidder seeking to communicate with NV Energy's transmission function personnel through this RFP process will have its proposal(s) summarily rejected if the attempt is not immediately withdrawn when discovered.** Bidders are required to execute the Voluntary Consent Form in Attachment B to this RFP that enables NV Energy's merchant function to discuss Bidder's interconnection and transmission service application(s) with the transmission interconnection or transmission service provider, including, if applicable, NV Energy's transmission function.

Bidder will cooperate with and provide information to any person or entity retained by NV Energy for purposes of evaluating Bidder's proposal.

Bidder shall not attempt to influence NV Energy in the evaluation of the proposals outside the solicitation process.

Bidder shall not participate in collusive bidding or any other anticompetitive behavior or conduct.

5.0 EVALUATION PROCEDURES AND CRITERIA

Each proposal will be initially evaluated by NV Energy to determine the proposal's conformance to the directives of this RFP bid protocol document and Bidder credit risk. **Proposals may be eliminated for non-conformance or due to credit risk.**

For each product in this RFP that passes the initial evaluation, NV Energy will conduct a two-stage process as part of its proposal evaluation and selection process leading up to selection of the preferred proposals for contract execution. In the first stage, NV Energy will conduct price, economic benefit (including job impacts) and non-price analyses, as well as a price screening

methodology designed to identify the lowest cost proposals for each product. NV Energy will select a shortlist based on those proposals for each product which have the highest overall score based on an evaluation of price, economic benefit and non-price factors. In the second stage, the shortlisted proposals will have the opportunity to refresh their prices; provided, however, that Bidders will not be permitted to increase the prices initially submitted with their proposal. The final proposals will then be modeled and evaluated based on the impact of the proposals on NV Energy's overall system costs. A more detailed description of each stage of the process is provided below.

NV Energy will conduct the two-stage evaluation and selection process independently for each of the proposals, by resource type. NV Energy will select and propose to the PUCN, for review and final approval, the proposal(s) that provide the best value to NV Energy's customers, considering all the factors described in this Section 5.

5.1 First Stage: Development of Initial Shortlists

The price, economic benefit and non-price forms in Attachment G will be used as a model to determine individual initial shortlists of proposals, separated by type of resource (i.e., wind, solar, geothermal, biomass, biogas and ESS systems). These resource-specific shortlists will be deemed the initial shortlists for further evaluation.²⁰

In considering a proposal, NV Energy will, in addition to considering the cost to customers, evaluate the following:

- (a) The greatest economic benefit to the State of Nevada;
- (b) The greatest opportunity for the creation of new jobs in the State of Nevada; and
- (c) The best value to customers of the electric utility.

Price factors will be analyzed to determine the LCOE or LCOS, as applicable, per MWh value of each proposal, and then ranked using the comparison metric described in Section 5.1.1 below. Price factors will recognize the value of the power associated with the delivery profile submitted in the proposal.

²⁰ See Section 3.2.2 for additional information on Attachment G.

Non-price factors considered by the Company fall into four general categories:

- 1) Bidder's project development and operational experience;
- 2) Technology and value attributes;
- 3) Conformity to the terms of the applicable pro forma agreements; and
- 4) Development milestones.

NV Energy intends to evaluate each proposal in a consistent manner by separately evaluating the non-price characteristics, economic benefit characteristics and the price characteristics of the proposal utilizing a proposal scorecard.

The proposal scorecard will include three factors, all of which may be viewed in Attachment G:

- 1) Price factor;
- 2) Non-price factor with four primary categories; and
- 3) Economic benefit factor with three categories.

Each component will be evaluated separately and recombined to determine the bundled price, economic benefit and non-price score. The price factor will be weighted up to 60%, the economic benefit factor will be weighted up to 10%, and the non-price factor will be weighted up to 30%. No proposal will receive a total weighting in excess of 100%. The price, economic benefit and non-price evaluations will be added together and used to determine the initial shortlist for each resource type. The initial shortlists in this RFP will be made up of the highest scoring proposals for each resource type.

5.1.1 Price Factor Evaluation (up to 60%)

A pricing model will be used to derive the LCOE per MWh value of each proposal (Products A and B, from Table 1) based on the price factors ("Proposal LCOE"). For ESS systems (Products C), the pricing model will derive the LCOS per MWh value of each proposal based on the price factors ("Proposal LCOS"). The Proposal LCOE and Proposal LCOS may also be referred to as the proposal levelized cost value ("Proposal LCV").

For each of the products, NV Energy will utilize a comparison metric to evaluate and determine the Proposal LCV ranking for the resource-specific initial shortlists.

The comparison metric will be the Proposal LCV per MWh. The Proposal LCV will be determined by calculating the present value of the annual cost over the term, converting the present value to an equivalent annual annuity and then dividing that annual annuity by the levelized annual energy provided. The discount rate will be the weighted average cost of capital as approved by the PUCN in NV Energy's most recent General Rate Case, as applicable. Project LCOE and LCOS will not be compared to one another. ESS systems and renewable energy systems will be evaluated separately.

5.1.2 Non-Price Factor (up to 30%)

The primary purpose of the non-price analysis is to help gauge the factors related to the proposal which are outside of price. The non-price factor will be weighted up to 30% in the determination of which proposals in this RFP will be chosen for each resource-specific initial shortlist. The scorecard will be used to score the non-price criteria under four categories: (1) Bidder's (or its development team's) project development experience; (2) technology and value attributes; (3) conformity to the terms of the pro forma agreement(s) and related exhibits; and (4) development milestones. The criteria for each of these four categories are set forth below.

Category 1 – Bidding Company/Development Team's Project Development Experience

- Project Development Experience
- Nevada, Federal or Tribal Lands Development Experience
- Ownership/O&M Experience
- Safety – Occupational Safety and Health Administration recordable incident rate
- Financial Capability

Category 2 – Technology and Value Attributes

- Technical Feasibility
- Resource Quality
- Equipment Supply Control
- Utilization of Resource

- Flexibility
- Environmental Benefits
- Fuel Diversity/Hedging
- Other Ancillary Services

Category 3 – Conformity to Pro forma Agreement(s) and Related Exhibits

- Magnitude of proposed revisions to pro forma agreement(s)

Category 4 – Development Milestones

- Land and Environmental Authorization Status/Feasibility
- Water Rights
- Project Financing Status
- Interconnection Progress
- Transmission Requirements (Network Upgrades)
- Reasonableness of COD as Demonstrated by Critical Path Schedule

5.1.3 Economic Benefits Factor (up to 10%)

The economic benefits to the state of Nevada will take into consideration the following matters, based on information submitted by Bidders, and NV Energy’s evaluation:

- Location of jobs created
 - Within the soliciting NV Energy service territory
 - Within the non-soliciting NV Energy service territory
 - Within the state of Nevada
- Number of *direct* jobs created in Nevada
 - Jobs created during construction
 - Jobs created during operation
- Economic *direct* benefits to Nevada
 - The direct value of expenditures made in Nevada attributed to the Project
 - Other *direct* economic benefits to Nevada

Please note, if project is selected, the values provided for jobs and economic benefits will be included in the regulatory filing for approval of the agreement, which is available to the public.

5.2 Second Stage: Best and Final Pricing

Proposals selected for the shortlist in each product will have an opportunity to refresh (in the form of Attachment G) their price to take into account further development of the project or updated pricing for equipment or other costs from the time the initial proposal was submitted to the time of “best and final” offer. Bidders are encouraged to lower their pricing or look for opportunities to enhance their production profiles (based, for example, on changes to equipment) and other means to increase the value of their proposals to NV Energy.²¹

Bidders that advance to the initial shortlist are also required to submit, along with their best and final pricing:

- Completed Attachment I – NAC 704 Requirements;
- Proposed reactive capability curves and single line diagrams of the facility; and
- A notice that Bidder has commenced discussions with the union(s) in accordance with Section 3.2.6.6 of this protocol.

5.2.1 The Final Shortlist

For each of the products, some or all of the proposals on the initial shortlists will then be evaluated using a production cost model to aid in determining the final shortlist based on the best and final pricing. NV Energy’s production cost model, used for integrated resource planning, will be used to determine a list of proposals deemed as the final shortlist. ESS systems will be evaluated separately.

In its analysis for this RFP, the Company will run some or all of the final shortlisted proposals and portfolios through its production cost model to determine the Present Worth Revenue Requirement (“PWRR”) of each alternative portfolio of resources.

NV Energy may choose to engage the final shortlist Bidders in further discussions or negotiations. Any such discussions or negotiations may be terminated by NV Energy at any time, for any reason.

²¹ A price increase at this stage will necessitate revisiting proposal rankings which may result in the proposal being removed from the initial shortlist.

5.3 Final Selection of Proposal(s)

The two stages described above constitute the formal evaluation process which will be utilized to select the proposals that will be submitted to the PUCN for approval. In addition to this two-stage analysis, in selecting the final proposals, NV Energy will consider the non-price factors qualitatively. Furthermore, NV Energy will also include in its evaluation any factor that may impact the total cost of a resource, including, but not limited to, all of the factors used in the initial shortlist cost analysis plus consideration of accounting treatment and potential effects due to rating agency treatment, if applicable.

6.0 AWARDING OF CONTRACTS

This RFP is merely an invitation to make proposals to the Company. No proposal in and of itself constitutes a binding contract. The Company may, in its sole discretion, perform any one or more of the following:

- Determine which proposals are eligible for consideration as proposals in response to this RFP.
- Issue additional subsequent solicitations for information and conduct investigations with respect to the qualifications of each Bidder.
- Supplement, amend, or otherwise modify this RFP, or cancel this RFP with or without the substitution of another RFP.
- Negotiate and request Bidders to amend any proposals.
- Select and enter into agreements with the Bidder(s) who, in the Company's sole judgment, is most responsive to this RFP and whose proposals best satisfy the interests of the Company, its customers, and state legal and regulatory requirements, and not necessarily on the basis of any single factor alone.
- Issue additional subsequent solicitations for proposals.
- Reject any or all proposals in whole or in part.
- Vary any timetable.
- Conduct any briefing session or further RFP process on any terms and conditions.
- Withdraw any invitation to submit a response.
- Select and enter into agreements with Bidder(s) for additional MW of renewable energy resources should additional demand be identified.

7.0 POST-BID NEGOTIATIONS

NV Energy may further negotiate both price and contract terms and conditions during post-bid negotiations. Post-bid negotiation will be based on NV Energy's cost and value assessment. NV Energy will continually update its economic and risk evaluations until both parties execute a definitive agreement acceptable to NV Energy. Transactions may be subject to the approval of the PUCN on terms and conditions that are satisfactory to NV Energy in its sole and absolute discretion.

ATTACHMENT A – CONFIDENTIALITY AGREEMENT

This attachment is available in electronic format in BHE JAGGAER.

ATTACHMENT B – VOLUNTARY CONSENT FORM

This attachment is available in electronic format in BHE JAGGAER.

ATTACHMENT C – PRO FORMA POWER PURCHASE AGREEMENT AND EXHIBITS

This attachment is available in electronic format in BHE JAGGAER.

ATTACHMENT D – PRO FORMA ASSET PURCHASE AGREEMENT AND EXHIBITS

This attachment is available in electronic format in BHE JAGGAER.

ATTACHMENT E – PRO FORMA BUILD TRANSFER AGREEMENT AND EXHIBITS

This attachment is available in electronic format in BHE JAGGAER.

ATTACHMENT F – PRO FORMA O&M TERM SHEET

This attachment is available in electronic format in BHE JAGGAER.

ATTACHMENT G – PROPOSAL INPUT FORMS

(Price, Non-Price and Economic Benefit Input Forms)

This attachment is available in electronic format in BHE JAGGAER. The contents of the workbook are as follows:

- 1) TOC (*Table of Contents*)
- 2) Scoring Structure
- 3) Evaluation Components
- 4) Corporate Information *
- 5) Price Input *
- 6) 8760 Prod. Profile *
- 7) Price Input –ESS *
- 8) Financial Inputs *
- 9) Non-Price Scoring
- 10) Non-Price Input *
- 11) Economic Benefit Scoring
- 12) Econ Benefit Input *
 - a. SolarPV *
 - b. Energy Storage *
 - c. Wind *
 - d. Geothermal *
 - e. Biopower *
 - f. Hydro *
 - g. Fossil *
- 13) Technology Specific Data
 - a. Solar Data *
 - b. Energy Storage Data *
 - c. Wind Data *
 - d. Geo Data *
 - e. Biopower Data *
 - f. Hydro Data *
 - g. Fossil Data *

*** Worksheet required to be completed by Bidder, as applicable to proposed product**

ATTACHMENT H – BIDDER PROPOSAL COMPLIANCE CHECKLIST

This attachment is available in electronic format in BHE JAGGAER.

ATTACHMENT I – NEVADA ADMINISTRATIVE CODE 704 REQUIREMENTS

This attachment is available in electronic format in BHE JAGGAER.

Bidders that advance to the initial shortlist are required to submit Attachment I along with their best and final pricing.

ATTACHMENT J – BIDDER’S SAFETY PLAN

(Outline of NV Energy’s Safety Plan, as Example)

This attachment is available in electronic format in BHE JAGGAER.

ATTACHMENT K – APPROVED VENDORS LIST²²

This attachment is available in electronic format in BHE JAGGAER.

The Approved Vendors List shall be included as an exhibit to any agreement executed by the parties.

²² This list is not intended to be an endorsement of the vendors listed or to be all-inclusive. It simply acknowledges the vendors that NV Energy has approved of as of the date of this document, and is subject to change.

ATTACHMENT L – RESERVED

ATTACHMENT M – RESERVED

ATTACHMENT N – FORM OF WORK SITE AGREEMENT

This attachment is available in electronic format in BHE JAGGAER.

The form of WSA, as modified, or an executed WSA, is to be inserted in the applicable exhibit of the agreement being proposed, unless the proposal is for Product 1 or Product 2 (as set forth in Table 1).

ATTACHMENT O – METERING SCHEME EXAMPLES

Energy Storage: NV Energy requires that all energy storage facilities have a dedicated bi-directional meter. For generation and storage facilities, the storage meter will be installed on the low-side common AC bus-side of the inverter(s). This meter will be used to track the energy used to charge the energy storage system as well as energy discharged from the energy storage system. Facilities utilizing energy storage system on a dedicated lead line will install a single high-side meter.

In addition to the required bi-directional energy storage system meter, NV Energy requires all generation facilities to have a high-side aggregate meter. This meter must be located on the high-side of the generator step-up transformer and will measure the total output of the interconnected facility.

With the addition of multiple complex generation facilities, NV Energy proposes the use of the following metering schemes for generation/storage facilities.

Scheme 1:

The configuration in Figure 1 shows a generation facility with two PV feeders and a battery storage feeder. The battery storage feeder is required to have an AC, low-side meter compensated to the point of interconnection (POI). The two PV feeders are under the same PPA and selling to the same company. A high-side meter accounts for the output of all three facilities. Since the PV feeders are under the same PPA, no additional meters are required.

Figure 1: Solar and Storage with Single GSU and Common PPA

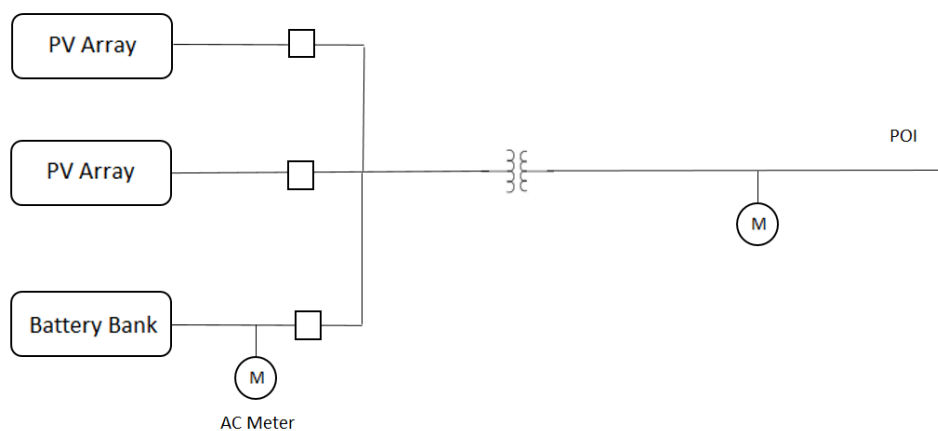

Scheme 2:

The configuration in Figure 2 is similar to Figure 1, except the solar feeders have different PPA's. In addition to the AC coupled battery storage meter, each solar feeder is required to have an individual meter. This allows each PPA to be metered while adhering to CAISO EIM requirements. NV Energy is currently working on an advanced metering system to dynamically allocate losses between all generation feeders. This will allow the low-side meters to accurately allocate line and transformer losses based on PV/storage production.

Figure 2: Solar and Storage with Single GSU and Multiple PPA's

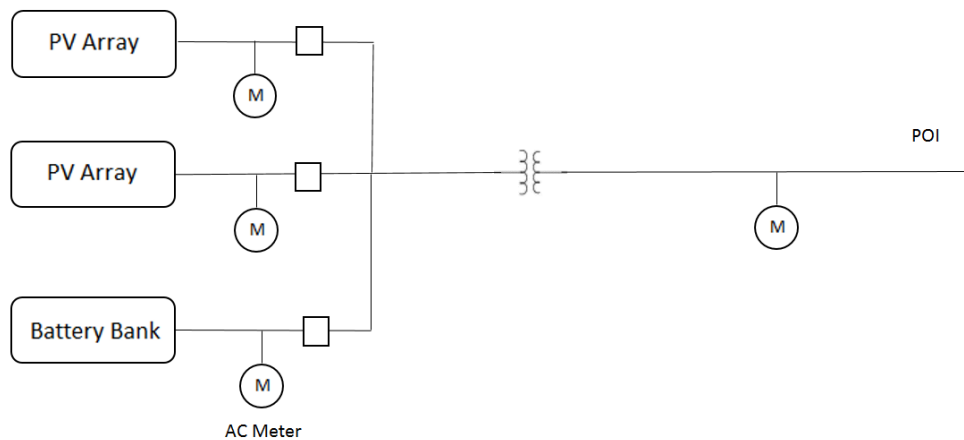

Scheme 3:

The configuration proposed in Figure 3 is for multiple GSU's and PPA's. This configuration is similar to Figure 2, except the addition of another GSU requires the inclusion of a common low-side meter. Each storage facility will continue to be required to have an AC meter. Each solar facility will be required to have a low-side meter measuring the gross output of the feeder. An additional common low-side meter is required to accurately allocate transformer and line losses using dynamic loss compensation.

Figure 3: Solar and Storage with Multiple GSU's and PPA's

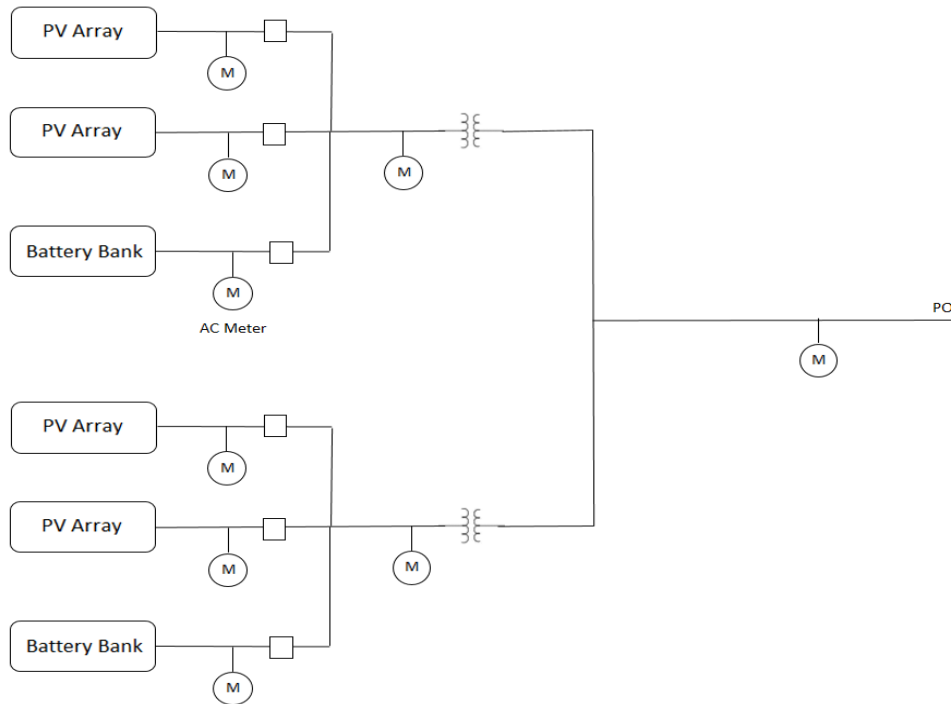

Scheme 4:

The configuration proposed in Figure 4 is for a single storage facility on a dedicated lead line. This configuration requires a high-side meter compensated to the POI. If multiple feeders of battery storage are added, each with separate PPA's, Scheme 2 will be required.

Figure 4: Single Battery Storage on a Dedicated Lead Line

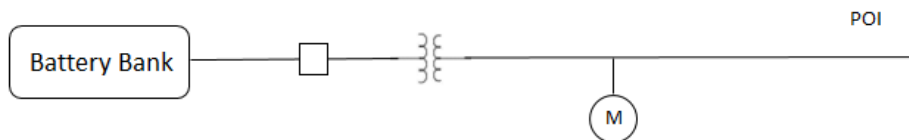

ATTACHMENT P – PROPOSAL ZIP FILE STRUCTURE

This attachment is available in electronic format in BHE JAGGAER.