

TOP VIEW

SAFETY – CUSTOMER’S RESPONSIBILITY:
BOTH WELL OPENINGS WILL BE COVERED/SECURED UPON THE INSTALLATION OF THE WELL.

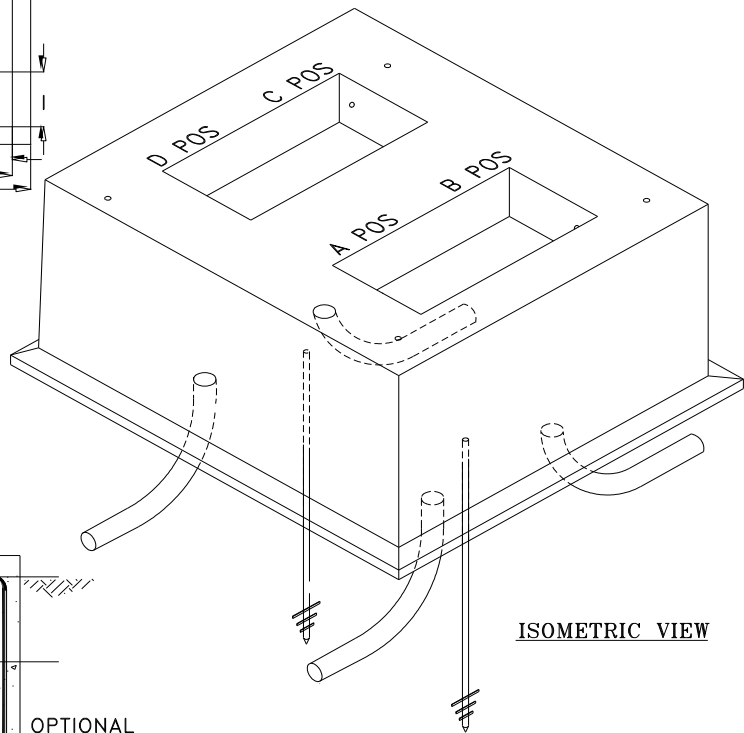

ISOMETRIC VIEW

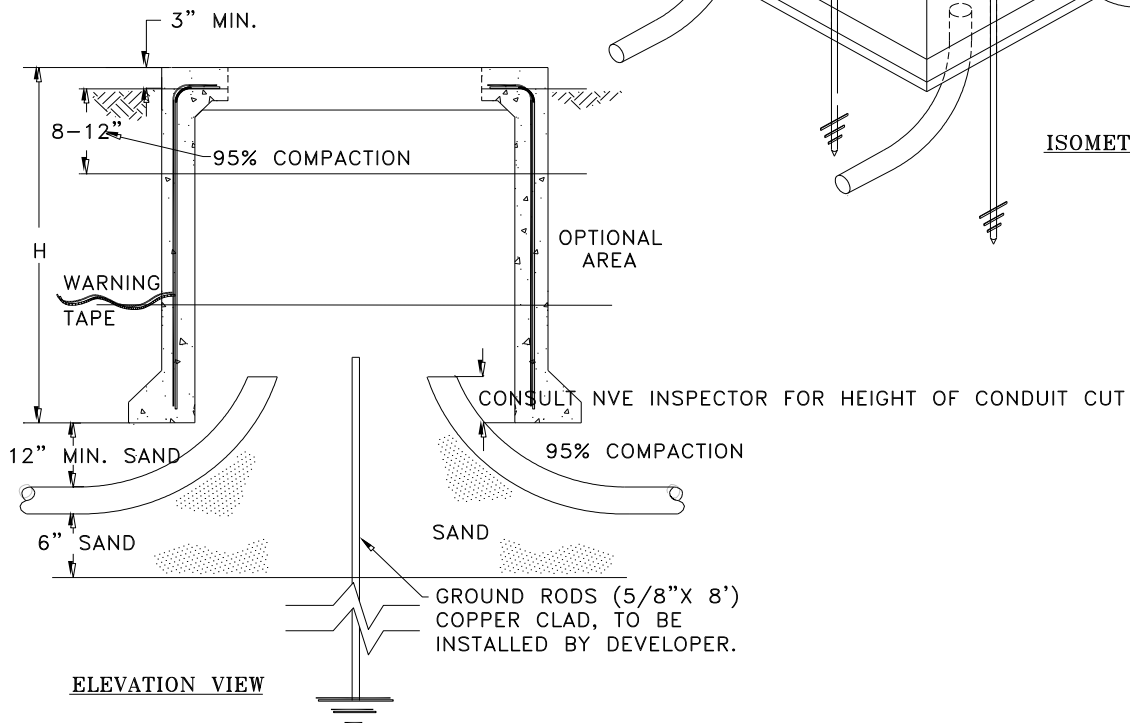

ELEVATION VIEW

| | | | | | | | |
|--------|------|-------|-------|---|--|----------------------------|--|
| | | | | VOLUME 17 – ENGINEERING & CONSTRUCTION STANDARD | | PE0016U PE0017U PE0018U | |
| | | | | 600 AMP 3Ø SWITCH PAD WELLDDETAILS | | | |
| Drawn: | Eng: | Appr: | Date: | | | | |
| RN | MB | DA | 8/11 | | | | |

| NVE DWG. # SWITCH PAD WELLS | A | A1 | B | B1 | C | D | E | F | G | H | I | J | K | WEIGHT (lbs.) |
|---|------|------|-----|-----|-----|---------|---------|-----|-----|-----|-----|-----|-----|------------------|
| PE0016U PADMOUNTED SWITCH PAD WELL STOCK # 24-0730 | 104" | 112" | 80" | 88" | 15" | 6" | 20" | 64" | 13" | 48" | 12" | 25" | 38" | 9500 |
| PE0017U PADMOUNTED SWITCH PAD WELL STOCK # 24-0734 | 104" | 112" | 80" | 88" | 15" | 10-1/2" | 20" | 64" | 17" | 48" | 12" | 25" | 29" | 9500 |
| PE0018U PADMOUNTED SWITCH PAD WELL STOCK # 24-0738 | 104" | 112" | 80" | 88" | 15" | 10-1/2" | 12-1/2" | 79" | 17" | 48" | 16" | 28" | 29" | 9500 |

CONSTRUCTION NOTES

1. CONDUITS TO BE IN PROPER CONFIGURATION TO ALLOW CONDUIT SPACING AND PLUGGED PER CD0001U, SECTION 12.1.
2. 8" - 12" TYPE 2 BACKFILL TO BE COMPACTED AT 95%. SEE SECTION 5.0 OF SUB01X, VOL. 17.
3. SAND AREA TO BE COMPACTED AT 90%. 12" OF SAND MUST COVER THE CONDUIT.
4. PAD WELLS ARE NOT MAN ACCESSIBLE, FUTURE POSITIONS MUST BE STUBBED, FISHED, WITH GROUND WIRES CONNECTED TO THE GROUND ROD AND POSITIONED TO BE ACCESSIBLE FROM WINDOW OPENINGS.
5. GROUND ROD (5/8" X 8' COPPER-CLAD), TO BE INSTALLED BY DEVELOPER TELEPHONE AND CABLE TV GROUND WIRE TO BE ATTACHED BY APPLICANT.

| | | | | | | | | | |
|--|------|-------|-------|---|--|--|--|----------------------------|--|
|  | | | | VOLUME 17 – ENGINEERING & CONSTRUCTION STANDARD | | | | PE0016U PE0017U PE0018U | |
| | | | | 600 AMP 3Ø SWITCH PAD WELLDDETAILS | | | | Revision: 4 Page 2 of 2 | |
| Drawn: | Eng: | Appr: | Date: | | | | | | |
| RN | MB | DA | 8/11 | | | | | | |