

DESIGN REQUIREMENTS

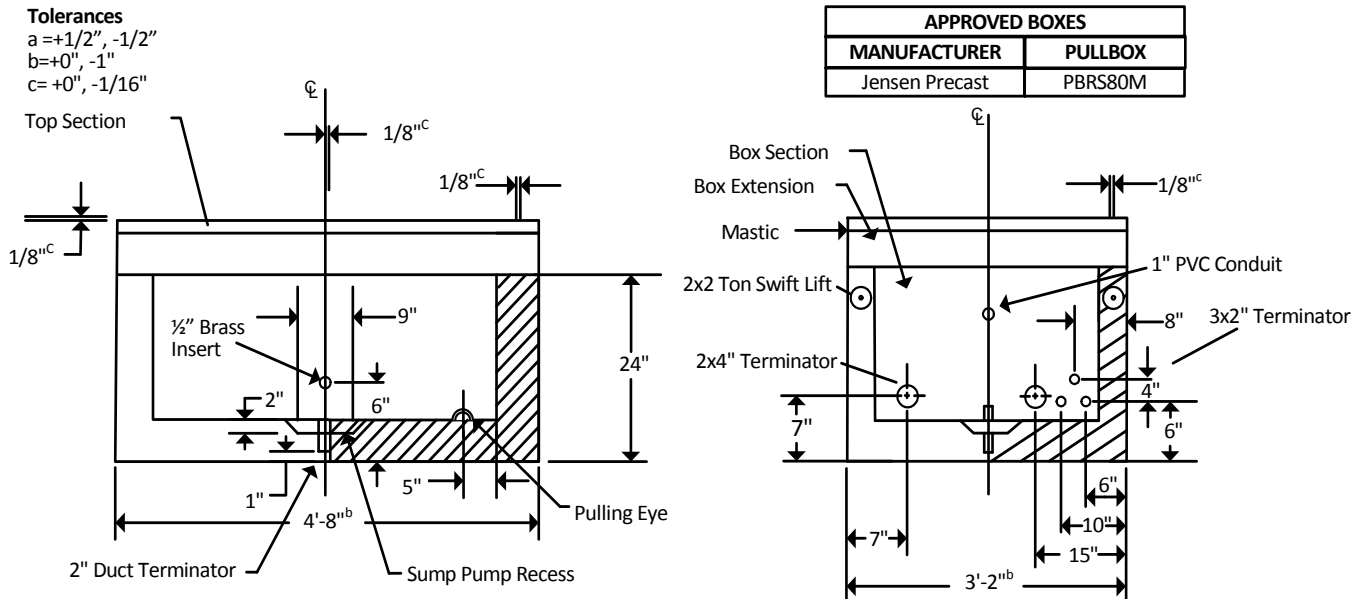

Figure 1. RS-80M SPLICE BOX

1. TOP SECTION (WITH TORSION ASSISTED LID)

1. "ELE" in 1" letters, centered, bead welded or impressed into the top of one lid section. Note: "NVE COMM" shall be used instead of "ELE" on all NVE communications lids.
2. Two 5/8" slotted holes with two captive 1/2" – 13 UNC 304 stainless steel penta head bolts and two angle brackets (see Figure 2), which shall be welded continuously to the side of the frame under the slotted holes.
3. Both lid sections level to the top of the frame.
4. A 1" diameter hole (for a typical lifting hook), in covering lid section, with a permanent internal safety cover.
5. Two stainless steel (filled with grease) or brass bearing hinges for each lid section.
6. A stainless steel safety pin and chain lanyard shall be installed with each hinge, and provision shall be made to secure each pin when not in use (see Figures 3 and 4 below). McMaster-Carr, Catalog No. 92730A120 and Catalog No. 98416A011, or equivalent shall be supplied.
7. Manufacturer shall provide provision(s) to lock each lid in the 90 degree open position.
8. Manufacturer shall provide a maximum 1/8" horizontal and vertical gap around lids with a debris shield welded on the back side of lids (see Figure 5).
9. Manufacturer shall provide anchoring provision(s), at both ends of the frame.
10. The gap between the precast structure and the lid shall be sealed with mastic or similar material approved by NVE (see Figure 1).

				Electric Service Requirements		<b>RS-80M</b>
				<b>Splice Box:</b> <b>30" x 48" x 20"</b> <b>(Maintenance Only)</b>		
Drawn:	Eng:	Appr:	Date:			Revision: 01
SM	RD	DA	8/17			Page 1 of 6

# Vaults and Boxes



**Figure 2**

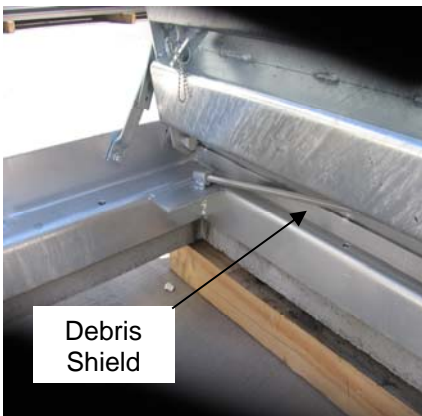

**Figure 3**



**Figure 4**

11. The frame bolted to the precast extension, and the gap sealed with mastic or similar material approved by NVE. Two (2) ½” hexagon torsion bars are to be used for each lid. The material shall be 4140 Annealed or 5160 ASQ. Bars to be heat treated to R/C 42-44 and straightened and then cold galvanized or electroplated to prevent corrosion. Design is to allow for easy replacement of torsion bars. Material and heat treating certifications shall be provided on request.
12. Maximum 35 lb. pulling force required to open each lid section.
13. The open angle (by torsion bars) not to exceed 15 degrees between the lid and the frame.
14. An identification tag with the cover manufacturer name, model number and year of manufacture shall be installed on the inside frame.
15. Every twentieth top section assembled, tested by opening and closing the lid 25 times.
16. Four (4) captive ½” bolts shall be attached to the frame one in each corner of lid not to interfere with safety latch, for adjusting the cover to grade variations. Bolt length shall be sized to limit adjustment to no more than 3” (see Figure 6).
17. Manufacturer shall provide a place to attach bonding wire at each end of lid frame and install a 3’- #4 copper (stranded) covered bonding wire, shall be green in color using listed connectors.(see Figure 7).



**Figure 5.**



**Figure 6.**



**Figure 7.**

## 2. BOX EXTENSION

1. 30” (W) X 48” (L) inside dimensions with tolerances of ± 1”.

				Electric Service Requirements		<b>RS-80M</b>
				<b>Splice Box: 30”x 48”x 20” (Maintenance Only)</b>		
Drawn:	Eng:	Appr:	Date:			Revision: 01
SM	RD	DA	8/17			Page 2 of 6

## Vaults and Boxes

---

### 3. BOX SECTION

1. Three 2" and two 4" diameter PVC conduit terminators through each end wall.
2. One 1" diameter PVC conduit through each end wall.
3. A 9" diameter x 2" deep sump pump recess with 2" diameter Duct Terminator in the middle of the floor. Per T & D Standards, Bow Co. Industries Inc. Part # T2000 or equivalent.
4. Two steel pulling eyes in the floor.
5. 30" (W) x 48" (L) inside dimensions with tolerances of  $\pm 1"$ .
6. One  $\frac{1}{2}"$  brass insert on each side wall.

### 4. ENTIRE STRUCTURE

1. All exposed steel shall be hot dip galvanized after fabrication, except torsion bars.
2. Torsion bars shall be spray galvanized.
3. Shall meet RS-G2 and RS-G4.  
**NOTE:** For traffic areas (e.g., streets, roads, etc.), use the RS-83 box.
4. For other areas subject to vehicular traffic, vehicular protection barriers per RS-6 shall protect RS-80M boxes.

### 5. GROUNDING

The inserts shall be spaced in accordance with this specification drawing. Inserts to be attached to the internal box rebar by spot welding or approved connector. The insert shall accept  $\frac{1}{2}"$ -13 UNC Thread. Continuity between all inserts installed in the box sections shall be checked and verified prior to shipping by manufacturer / supplier.

				Electric Service Requirements		<b>RS-80M</b>
				<b>Splice Box: 30" x 48" x 20" (Maintenance Only)</b>		
Drawn:	Eng:	Appr:	Date:	Revision: 01		
SM	RD	DA	8/17	Page 3 of 6		

6. Installation Requirements

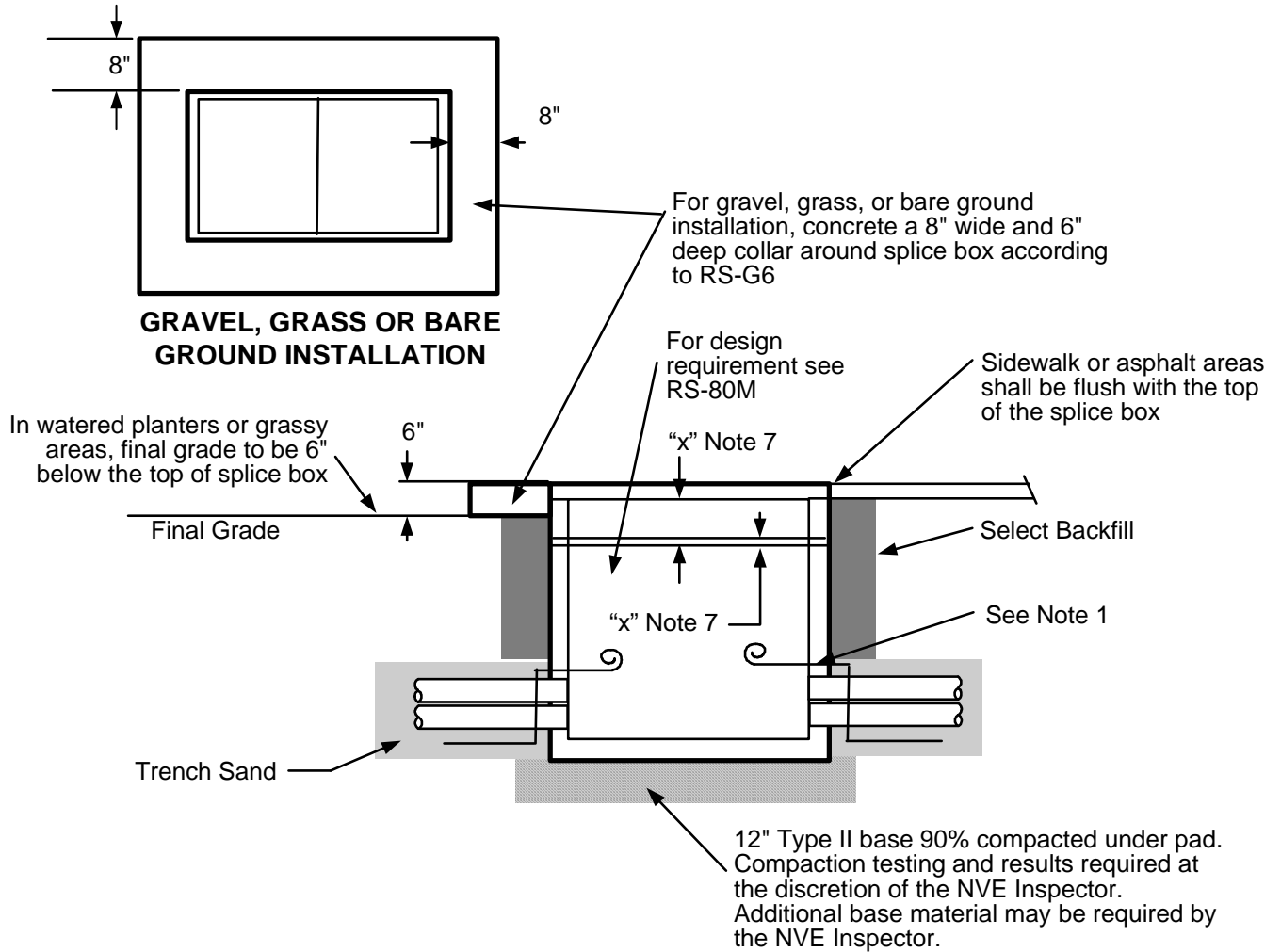

Figure 8. RS-80M Installation Requirements

**NOTES:**

1. Ground wires shall be installed through a 1" PVC conduit in the structures end walls. Grounding by customer shall consist of the following:
  - A. 2-50' lengths of #2-7 stranded bare copper ground wires laid in the bottom of the conduit trench in opposite directions.
  - B. An additional 5' of the ground wire will be left in the box.
  - C. No exceptions allowed.
2. This box shall be used as a splice box for primary cables (US-115) or for commercial secondary cables.
3. When this box is for commercial secondary cables, then the Designer shall specify on the construction drawing the required number of terminators and their locations.
4. If the final grade is unknown, it is preferable to make the top of the splice box too low, rather than too high.

				Electric Service Requirements		<b>RS-80M</b>
				<b>Splice Box:</b> <b>30" x 48" x 20"</b> <b>(Maintenance Only)</b>		
Drawn:	Eng:	Appr:	Date:			Revision: 01
SM	RD	DA	8/17			Page 4 of 6

## Vaults and Boxes

5. The bottom surface of the box shall be level.
6. If the ground water level is at least 3' below the bottom of the splice box, the 2" diameter knockout in the sump pump recess shall be removed.
7. All new installations to be set to final grade. Grade changes prior to cable installation will require the box to be raised or lowered. If any final grade adjustments are required after the cable is pulled, take the actions listed in Table 1.

**Table 1. Adjustment Requirements**

Adjustment	Action
-6" to +5"	NVE contractor shall exchange existing 12" extension with 6" to 17" high extension ordered from the original manufacturer.
+6" to +12"	NVE contractor may order an additional 6" to 12" height extension from original manufacturer.
Below -6" & above 12"	Any extension shorter than 6" or exceeding 12" in height shall be subject to T&D Standards department approval.

8. This box shall be installed in non-traffic areas only.  
**NOTE:** For traffic areas (e.g., streets, roads, etc.) use the RS-83 box
9. There shall be a minimum 6' clearance from the RS-80M box to the centerline of a fire hydrant.
10. Retaining wall required when grade from the top of the lid rises or lowers more than 1' in 5' horizontally or when required by developer as perimeter wall.
11. NV Energy lineman shall install # 2 bare copper bus to grounding inserts and attach all bonding wires.

				Electric Service Requirements		<b>RS-80M</b>
				<b>Splice Box:</b> <b>30" x 48" x 20"</b> <b>(Maintenance Only)</b>		
Drawn:	Eng:	Appr:	Date:			Revision: 01
SM	RD	DA	8/17			Page 5 of 6

THIS PAGE INTENTIONALLY LEFT BLANK

				Electric Service Requirements		<b>RS-80M</b>
				<b>Splice Box: 30" x 48" x 20" (Maintenance Only)</b>		
Drawn:	Eng:	Appr:	Date:	Revision: 01		
SM	RD	DA	8/17	Page 6 of 6		